

Agilent E1459A / Z2404B 64-Channel Isolated Input Interrupt Module

User's and SCPI Programming Manual

Where to Find it - Online and Printed Information:

System installation (hardware/software)	VXIbus Configuration Guide* Agilent VIC (VXI installation software)*
Module configuration and wiring	This Manual
SCPI programming	This Manual
SCPI example programs	This Manual
SCPI command reference	This Manual
Register-Based Programming	This Manual
VXI <i>plug&play</i> programming	VXI <i>plug&play</i> Online Help
VXI <i>plug&play</i> example programs	VXI <i>plug&play</i> Online Help
VXI <i>plug&play</i> function reference	VXI <i>plug&play</i> Online Help
Soft Front Panel information	VXI <i>plug&play</i> Online Help
VISA language information	Agilent VISA User's Guide
Agilent VEE programming information	Agilent VEE User's Manual



**Supplied with Agilent Command Modules, Embedded Controllers, and VXLink.*



Agilent Technologies



Warranty	5
Safety Symbols	6
WARNINGS	6
Declaration of Conformity	7
User Notes.....	8

Chapter 1

Installing and Configuring the Agilent E1459A	11
Functional Description.....	11
Watchdog Timer	14
Input Level Selection	14
Input Isolation	14
Input Debounce Processing	14
Input Edge Detection	15
Input Data Capture	17
Front Panel Markers	18
Interrupt Driven or Polled Mode Operations	18
Interrupt Parsing	18
Configuring for Installation	19
Setting the Logical Address	20
Setting the Interrupt Priority	20
Setting Input Threshold Levels	21
Setting the Reset Time on the Watchdog Timer	21
Connecting User Inputs	22
Installing the Agilent E1459A in a VXIbus Mainframe	24
Terminal Block	25
Wiring a Terminal Block	26

Chapter 2

Using the Agilent E1459A Module	29
Power-on / Reset States	30
Example 1: Reset, Self Test, and Module ID	30
Example 2: Digital Input	32
Edge Detected Event Detection	34
Example 3: Edge Interrupt	37

Chapter 3

Agilent E1459A SCPI Command Reference	39
DIAGnostic:SYSReset Subsystem	41
DIAGnostic:SYSReset[:STATe]?	41
DIAGnostic:SYSReset:ENABle <state>	41
DIAGnostic:SYSReset:ENABle?	42
DISPlay:MONitor Subsystem.....	43
DISPlay:MONitor:PORT <port>	43
DISPlay:MONitor:PORT? [MINimum MAXimum DEFault]	44
DISPlay:MONitor:PORT:AUTO <state>	44
DISPlay:MONitor:PORT:AUTO?	44
DISPlay:MONitor[:STATe] <state>	45
DISPlay:MONitor[:STATe]?	45
INPut Subsystem.....	46
INPutn:CLOCK[:SOURce] <source>	46
INPutn:CLOCK[:SOURce]?	47
INPutn:DEBounce:TIME <time> MINimum MAXimum DEFault	47
INPutn:DEBounce:TIME? [MINimum MAXimum DEFault]	48
MEASure Subsystem.....	49
MEASure:DIGital:DATAn[:type] [:VALue]?	49
MEASure:DIGital:DATAn[:type]:BITm?	50
MEMory Subsystem	51
MEMory:DELete:MACRo <name>	51
SENSe Subsystem.....	52
[SENSe:]EVENT:PORTn:DAVailable?	52
[SENSe:]EVENT:PORTn:DAVailable:ENABle <state>	53
[SENSe:]EVENT:PORTn:DAVailable:ENABle?	53
[SENSe:]EVENT:PORTn:EDGE?	54
[SENSe:]EVENT:PORTn:EDGE:ENABle <state>	54
[SENSe:]EVENT:PORTn:EDGE:ENABle?	55
[SENSe:]EVENT:PORTn:NEDGE?	55
[SENSe:]EVENT:PORTn:NEDGE:ENABle <mask>	56
[SENSe:]EVENT:PORTn:NEDGE:ENABle?	56
[SENSe:]EVENT:PORTn:PEDGe?	57
[SENSe:]EVENT:PORTn:PEDGe:ENABle <mask>	57
[SENSe:]EVENT:PORTn:PEDGe:ENABle?	58
[SENSe:]EVENT:PSUMmary:DAVailable?	58
[SENSe:]EVENT:PSUMmary:EDGE?	59
STATus Subsystem.....	60
STATus:OPERation:CONDition?	62
STATus:OPERation:ENABle <mask>	62
STATus:OPERation:ENABle?	63
STATus:OPERation[:EVENT]?	63
STATus:OPERation:PSUMmary:CONDition?	63
STATus:OPERation:PSUMmary:ENABle <mask>	64
STATus:OPERation:PSUMmary:ENABle?	64
STATus:OPERation:PSUMmary[:EVENT]?	65
STATus:PRESet	65

STATus:QUEStionable:CONDition?	66
STATus:QUEStionable:ENABle <mask>	66
STATus:QUEStionable:ENABle?	67
STATus:QUEStionable[:EVENT]?	67
SYSTem Subsystem	68
SYSTem:CDEscription? <number>	68
SYSTem:CTYPE? <number>	68
SYSTem:ERRor?	69
SYSTem:VERSion?	69
IEEE 488.2 Common Commands.....	70
Command Quick Reference.....	71

Appendix A

Agilent E1459A Specifications	73
--	-----------

Appendix B

Agilent E1459A Register Definitions	75
Overview.....	75
Addressing the Registers	76
Register Access with Logical Address	76
Register Access with Memory Mapping	76
Register Definitions	77
Manufacturer ID Register	78
Device Type Register	78
Status/Control Register	78
Edge Interrupt Status Register	80
Data Available Status Register	80
Watchdog Timer Control/Status Register	81
Command Register Port 0/2	81
Channel Data Register Port 0/2	83
Positive Edge Detect Register Port 0/2	83
Negative Edge Detect Register Port 0/2	84
Positive Mask Register Port 0/2	84
Negative Mask Register Port 0/2	84
Debounce Clock Register Port 0 and Port1/ Port 2 and Port 3	85
Command Register Port 1/3	86
Channel Data Register Port 1/3	87
Positive Edge Detect Register Port 1/3	88
Negative Edge Detect Register Port 1/3	88
Positive Mask Register Port 1/3	88
Negative Mask Register Port 1/3	89
Debounce Clock Register Port 0 and Port 1/ Port 2 and Port 3	89
Power On/Reset Conditions.....	91
Programming Examples.....	91
Output and Edge Detection Examples	92

Appendix C

Error Messages	105
-----------------------------	------------

Certification

Agilent Technologies, Inc. certifies that this product met its published specifications at the time of shipment from the factory. Agilent Technologies further certifies that its calibration measurements are traceable to the United States National Institute of Standards and Technology (formerly National Bureau of Standards), to the extent allowed by that organization's calibration facility, and to the calibration facilities of other International Standards Organization members.

AGILENT TECHNOLOGIES WARRANTY STATEMENT

PRODUCT: E1459A

DURATION OF WARRANTY: 1 year

1. Agilent warrants Agilent hardware, accessories and supplies against defects in materials and workmanship for the period specified above (one year). If Agilent receives notice of such defects during the warranty period, Agilent will, at its option, either repair or replace products which prove to be defective. Replacement products may be either new or like-new.
2. Agilent warrants that Agilent software will not fail to execute its programming instructions, for the period specified above, due to defects in material and workmanship when properly installed and used. If Agilent receives notice of such defects during the warranty period, Agilent will replace software media which does not execute its programming instructions due to such defects.
3. Agilent does not warrant that the operation of Agilent products will be interrupted or error free. If Agilent is unable, within a reasonable time, to repair or replace any product to a condition as warranted, customer will be entitled to a refund of the purchase price upon prompt return of the product.
4. Agilent products may contain remanufactured parts equivalent to new in performance or may have been subject to incidental use.
5. The warranty period begins on the date of delivery or on the date of installation if installed by Agilent. If customer schedules or delays Agilent installation more than 30 days after delivery, warranty begins on the 31st day from delivery.
6. Warranty does not apply to defects resulting from (a) improper or inadequate maintenance or calibration, (b) software, interfacing, parts or supplies not supplied by Agilent Technologies, (c) unauthorized modification or misuse, (d) operation outside of the published environmental specifications for the product, or (e) improper site preparation or maintenance.
7. TO THE EXTENT ALLOWED BY LOCAL LAW, THE ABOVE WARRANTIES ARE EXCLUSIVE AND NO OTHER WARRANTY OR CONDITION, WHETHER WRITTEN OR ORAL, IS EXPRESSED OR IMPLIED AND AGILENT SPECIFICALLY DISCLAIMS ANY IMPLIED WARRANTY OR CONDITIONS OF MERCHANTABILITY, SATISFACTORY QUALITY, AND FITNESS FOR A PARTICULAR PURPOSE.
8. Agilent will be liable for damage to tangible property per incident up to the greater of \$300,000 or the actual amount paid for the product that is the subject of the claim, and for damages for bodily injury or death, to the extent that all such damages are determined by a court of competent jurisdiction to have been directly caused by a defective Agilent product.
9. TO THE EXTENT ALLOWED BY LOCAL LAW, THE REMEDIES IN THIS WARRANTY STATEMENT ARE CUSTOMER'S SOLE AND EXCLUSIVE REMEDIES. EXCEPT AS INDICATED ABOVE, IN NO EVENT WILL AGILENT OR ITS SUPPLIERS BE LIABLE FOR LOSS OF DATA OR FOR DIRECT, SPECIAL, INCIDENTAL, CONSEQUENTIAL (INCLUDING LOST PROFIT OR DATA), OR OTHER DAMAGE, WHETHER BASED IN CONTRACT, TORT, OR OTHERWISE.

FOR CONSUMER TRANSACTIONS IN AUSTRALIA AND NEW ZEALAND: THE WARRANTY TERMS CONTAINED IN THIS STATEMENT, EXCEPT TO THE EXTENT LAWFULLY PERMITTED, DO NOT EXCLUDE, RESTRICT OR MODIFY AND ARE IN ADDITION TO THE MANDATORY STATUTORY RIGHTS APPLICABLE TO THE SALE OF THIS PRODUCT TO YOU.

U.S. Government Restricted Rights

The Software and Documentation have been developed entirely at private expense. They are delivered and licensed as "commercial computer software" as defined in DFARS 252.227- 7013 (Oct 1988), DFARS 252.211-7015 (May 1991) or DFARS 252.227-7014 (Jun 1995), as a "commercial item" as defined in FAR 2.101(a), or as "Restricted computer software" as defined in FAR 52.227-19 (Jun 1987)(or any equivalent agency regulation or contract clause), whichever is applicable. You have only those rights provided for such Software and Documentation by the applicable FAR or DFARS clause or the Agilent standard software agreement for the product involved.

IEC Measurement Category II Overvoltage Protection

This is a measurement Category II product designed for measurements at voltages up to 300V from earth, including measurements of voltages at typical mains socket outlets. The product should not be used to make voltage measurements on a fixed electrical installation including building wiring, circuit breakers, or service panels.

E1459A 64-Channel Isolated Input Interrupt Module User's and SCPI Programming Manual



Edition 3 Rev 2
Copyright © 1997-2006 Agilent Technologies, Inc. All Rights Reserved.

Documentation History

All Editions and Updates of this manual and their creation date are listed below. The first Edition of the manual is Edition 1. The Edition number increments by 1 whenever the manual is revised. Updates, which are issued between Editions, contain replacement pages to correct or add additional information to the current Edition of the manual. Whenever a new Edition is created, it will contain all of the Update information for the previous Edition. Each new Edition or Update also includes a revised copy of this documentation history page.

Edition 1 (Part Number Z2404-90000) August 1991

Edition 2 (Part Number Z2404-90001) February 1996

Edition 3 (Part Number E1459-90001) July 1997

Edition 3 Rev 2 (Part Number E1459-90001) July 2006

Safety Symbols



Instruction manual symbol affixed to product. Indicates that the user must refer to the manual for specific WARNING or CAUTION information to avoid personal injury or damage to the product.



Alternating current (AC)



Direct current (DC).



Indicates hazardous voltages.



Indicates the field wiring terminal that must be connected to earth ground before operating the equipment—protects against electrical shock in case of fault.

WARNING

Calls attention to a procedure, practice, or condition that could cause bodily injury or death.

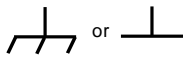

Frame or chassis ground terminal—typically connects to the equipment's metal frame.

CAUTION

Calls attention to a procedure, practice, or condition that could possibly cause damage to equipment or permanent loss of data.

WARNINGS

The following general safety precautions must be observed during all phases of operation, service, and repair of this product. Failure to comply with these precautions or with specific warnings elsewhere in this manual violates safety standards of design, manufacture, and intended use of the product. Agilent Technologies, Inc. assumes no liability for the customer's failure to comply with these requirements.

Ground the equipment: For Safety Class 1 equipment (equipment having a protective earth terminal), an uninterruptible safety earth ground must be provided from the mains power source to the product input wiring terminals or supplied power cable.

DO NOT operate the product in an explosive atmosphere or in the presence of flammable gases or fumes.

For continued protection against fire, replace the line fuse(s) only with fuse(s) of the same voltage and current rating and type. DO NOT use repaired fuses or short-circuited fuse holders.

Keep away from live circuits: Operating personnel must not remove equipment covers or shields. Procedures involving the removal of covers or shields are for use by service-trained personnel only. Under certain conditions, dangerous voltages may exist even with the equipment switched off. To avoid dangerous electrical shock, DO NOT perform procedures involving cover or shield removal unless you are qualified to do so.

DO NOT operate damaged equipment: Whenever it is possible that the safety protection features built into this product have been impaired, either through physical damage, excessive moisture, or any other reason, REMOVE POWER and do not use the product until safe operation can be verified by service-trained personnel. If necessary, return the product to an Agilent Technologies Sales and Service Office for service and repair to ensure that safety features are maintained.

DO NOT service or adjust alone: Do not attempt internal service or adjustment unless another person, capable of rendering first aid and resuscitation, is present.

DO NOT substitute parts or modify equipment: Because of the danger of introducing additional hazards, do not install substitute parts or perform any unauthorized modification to the product. Return the product to an Agilent Technologies Sales and Service Office for service and repair to ensure that safety features are maintained.

DECLARATION OF CONFORMITY

According to ISO/IEC Guide 22 and CEN/CENELEC EN 45014

Manufacturer's Name: Agilent Technologies, Incorporated
Manufacturer's Address: *Measurement Product Generation Unit*
815 14th ST. S.W.
Loveland, CO 80537 USA

Declares, that the product

Product Name: 64 Channel Isolated Digital Input/Interrupt
Model Number: E1459A
Product Options: *This declaration covers all options of the above product(s).*

Conforms with the following European Directives:

The product herewith complies with the requirements of the Low Voltage Directive 73/23/EEC and the EMC Directive 89/336/EEC and carries the CE Marking accordingly

Conforms with the following product standards:

EMC	Standard	Limit
	<i>IEC 61326-1:1997+A1:1998 / EN 61326-1:1997+A1:1998 CISPR 11:1997 +A1:1997 / EN 55011:1998 IEC 61000-4-2:1995+A1:1998 / EN 61000-4-2:1995 IEC 61000-4-3:1995 / EN 61000-4-3:1995 IEC 61000-4-4:1995 / EN 61000-4-4:1995 IEC 61000-4-5:1995 / EN 61000-4-5:1995 IEC 61000-4-6:1996 / EN 61000-4-6:1996 IEC 61000-4-11:1994 / EN 61000-4-11:1994</i>	<i>Group 1 Class A ^[1] 4kV CD, 8kV AD 3 V/m, 80-1000 MHz 0.5kV signal lines, 1kV power lines 0.5 kV line-line, 1 kV line-ground 3V, 0.15-80 MHz 1 cycle, 100%</i>
	<i>Canada: ICES-001:1998 Australia/New Zealand: AS/NZS 2064.1</i>	
Safety	<i>IEC 61010-1:1990+A1:1992+A2:1995 / EN 61010-1:1993+A2:1995 Canada: CSA C22.2 No. 1010.1:1992 UL 3111-1:1994</i>	

Supplemental Information:

^[1] *The product was tested in a typical configuration with Agilent Technologies test systems.*

September 5, 2000

Date



Name

Quality Manager

Title

For further information, please contact your local Agilent Technologies sales office, agent or distributor.

Authorized EU-representative: Agilent Technologies Deutschland GmbH, Herrenberger Strabe 130, D 71034 Böblingen, Germany

Notes:

Notes:

Notes:

Chapter 1

Installing and Configuring the E1459A

The Agilent E1459A 64-Channel Isolated Digital Input/Interrupt module (formerly known as the Z2404B¹) provides 64 isolated digital input channels configured as four 16-bit ports. The module is used for sensing signals and detecting edge changes on digital inputs. The module is a C-Size VXIbus register-based product that operates in a C-Size VXIbus mainframe.

Each isolated channel can withstand up to 115 Vac RMS or 115 Vdc difference in ground potential between channels. The input threshold for each channel is selectable with a jumper to allow for inputs with high logic levels from 5 to 48 volts. Each channel can be individually masked to generate an interrupt on a positive and/or negative edge transition. Channel inputs are also "debounced" to help prevent erroneous transition detection on noisy signals. Two programmable clock sources control the debounce circuitry (one for ports 0 and 1, one for ports 2 and 3).

Functional Description

The Agilent E1459A simultaneously monitors each channel for the occurrence of transitions, (i.e., edge events), or for level sensing signals which meet preprogrammed parameters for magnitude and duty. Each channel is electrically isolated from all other channels, power, ground, and other current paths within the limits of specification. Each channel may be independently programmed to sense only positive transitions, only negative transitions, or transitions of either polarity.

Figure 1-1 shows the functional block diagram for the module.

1. The Agilent E1459A and Z2404B are functionally identical. The Agilent E1459A is provided with a downloadable SCPI driver and a *VXIplug&play* driver; the Z2404B was not provided with a language driver.

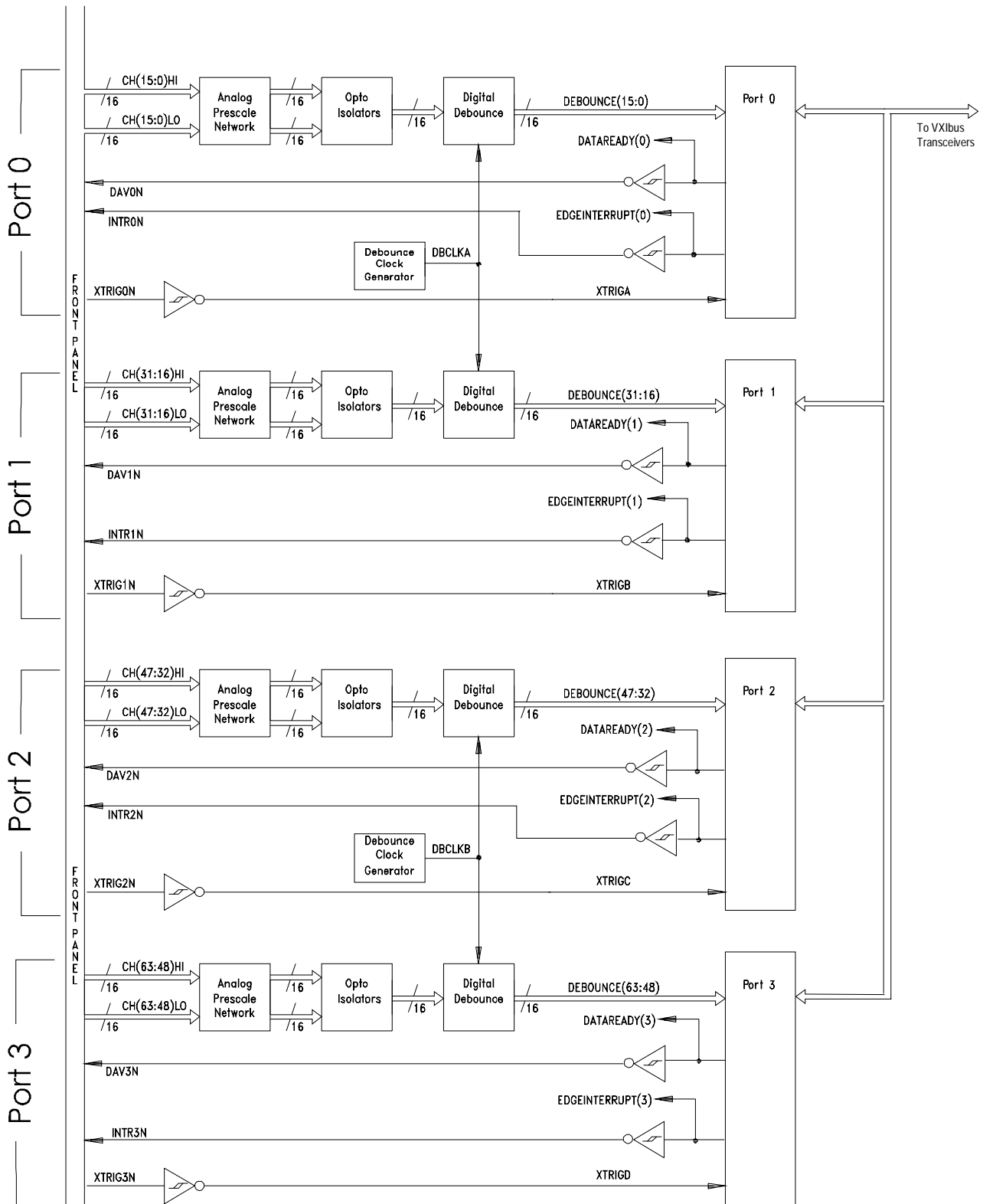

Figure 1-1. Agilent E1459A 64-Channel Isolated Digital Input/Interrupt Block Diagram

The Agilent E1459A can be programmed to monitor channel occurrences either internally with a 1.0 MHz sample clock, or externally, with a sourced capture clock. Using either clocking technique, data channels may function as edge detect inputs and/or data capture inputs.

Events at any channel may occur simultaneously or in overlap with events on any other channel. Figure 1-2 is a block diagram of the hardware interrupt resolver circuit. User software algorithms are also necessary to resolve issues of overlap and to determine the occurring sequence of events.

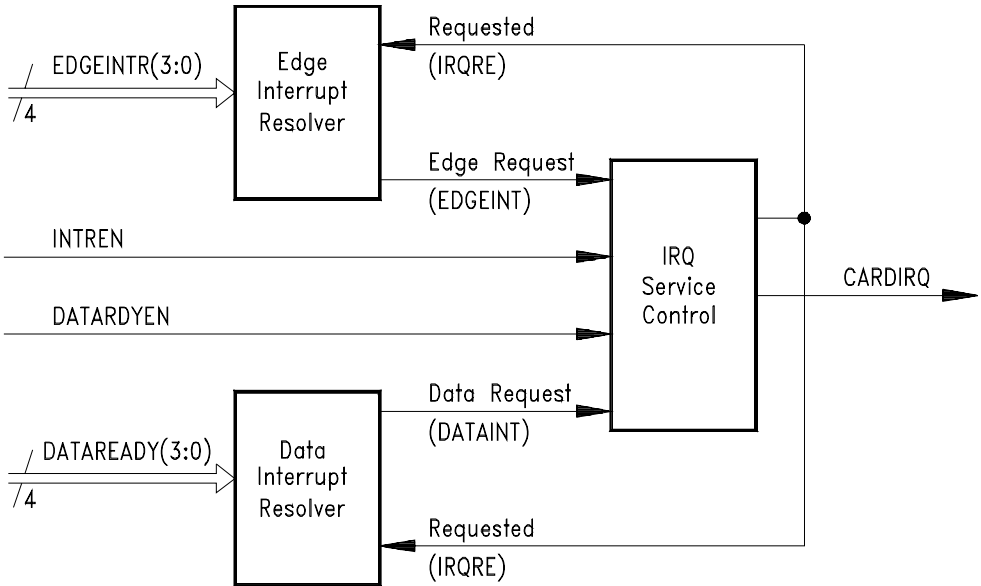

Figure 1-2. Resolver Block Diagram

Watchdog Timer

The Agilent E1459A provides a programmable timer facility which, in the event of time-out, will generate a "system wide" reset to all other card-cage modules. This timer may be disabled by the SCPI command `DIAG:SYSR:ENAB OFF`.

Input Level Selection

Each channel is capable of operation over an input range from 2.0 through 60.0 Vdc. Input voltages are grouped into voltage ranges which are selected via a series of jumpers on the module. These jumpers are described in more detail beginning on page 21.

Input Isolation

Each channel is optically coupled and electrically isolated from all other channels and current paths. Isolated channel inputs are polarized and require that the user observe input signal polarity when connections are made.

Input Debounce Processing

Each channel is debounced by a digital circuit specific to this function. Two programmable clock sources establish reference parameters which determine the debounce criteria for validating inputs. Channels are not independently programmed for debounce period, but are instead grouped together in blocks of 32 channels per clock source. Channels 00-31 (Ports 0 and 1) are collectively programmed via one clock source and channels 32-63 (Ports 2 and 3) are programmed via a second clock source.

Programmable Debounce Parameters

Debounce circuits require that a channel input remain in a stable state for 4 to 4.5 periods of the programmable clock before a channel transition is declared. The debounce clocks may be programmed for frequencies ranging from 250 KHz down to 466 μ Hz. The 4 to 4.5 clock period requirements of the debouncers translate into debounce periods which range from 16 μ S minimum to 9600 seconds (2.67 hours) maximum.

The debounce circuits can add considerable latency in the signal path and an additional delay occurs within the Register FPGA. Normally the signals pass through without significant delay. However, during a VXIbus transaction to this port, the input signals are momentarily captured by a latch and are held for the duration of the bus transaction plus 500 nS. This prevents data events from being lost due to potential timing conflicts with VXIbus transactions. The data signals are then synchronized with the system clock and synchronously captured in either the data register, the positive edge event register, or the negative edge event register. This can potentially add another 500 nS depending upon timing circumstances.

Thus the input data is delayed by the debounce circuits, possibly by the input latches (equal to bus transaction time plus 500 nS), and a synchronizing delay of 500 nS. The external clocks (front panel external trigger inputs) are also delayed but by no more than 500 nS. Therefore, an external capture clock concurrent with a data event will not capture the event unless consideration is given for data latency.

Caution The user **MUST** ensure, based upon the programmed debounce period and internal delays, that data to be captured has propagated the debouncers and is fully setup prior to the assertion of the externally generated capture clock.

The module has two primary modes of operation: the module can interrupt your software when an event occurs or your software can periodically poll the module to determine if an event has occurred. If the channel data registers are serviced via a "polled mode" method (which is not keyed to the posting of the "marker bits" or the occurrence of an interrupt), no timing relationship will necessarily exist with the debounced event. As a result, a small window of uncertainty exists between input latch timing and debounce circuit timing.

Input Edge Detection

Each channel may be programmed to sense the occurrence of a qualified edge transition of either polarity, or both concurrently. All channels are preprocessed via the debounce circuits before presentation to the edge detect logic. Edge detection is performed (by sampling methods) within each of the four ports, in groups of 16 channels per port. If enabled, each port will post an "Edge Interrupt Marker" to the control logic circuitry on the occurrence of a qualified edge event for any active channel within its channel group. (The static state of these markers may be tested via the "Edge Interrupt Status Register." These markers are also accessible at the front panel.)

Caution **Edge Detect Markers are cleared by a read of the register causing the marker to be posted. Since there is no high-level method of determining whether a positive or negative edge event is generating the marker, both edge detect registers (positive and negative) within a channel group, MUST be read during the service interval to identify ALL edge events which may have potentially occurred.**

Each marker bit is forced inactive for a two clock (16 MHz) periods each time either edge detect register is read. (The edge detect register is then cleared at the end of the cycle.) If the register that is not being read is inactive and remains inactive, the marker will continue to remain inactive. If the register that is not read is active or becomes active, the marker is again posted to the "control" logic. The control logic detects this event and stores this occurrence in a flip-flop which marks the pending need for service. If this marking register, (now active), is then read and ultimately cleared, the marker will become inactive and will remain inactive until the subsequent occurrence of another qualified edge event. The control logic detects this "cleared marker condition" and consequently clears the pending service request flip-flop.

External edge events which occur concurrently with a register read/clear cycle are queued and post-processed on completion of the cycle.

Edge Detection Examples

Figure 1-3 demonstrates a typical example. A channel that has been programmed to detect both positive and negative edge transitions posts a marker at the occurrence of a positive edge. Before user software can service this interrupt, a negative transition occurs and is detected. Because both are detected and the events are marked, user software first reads the positive edge detect register and then the negative edge detect register.

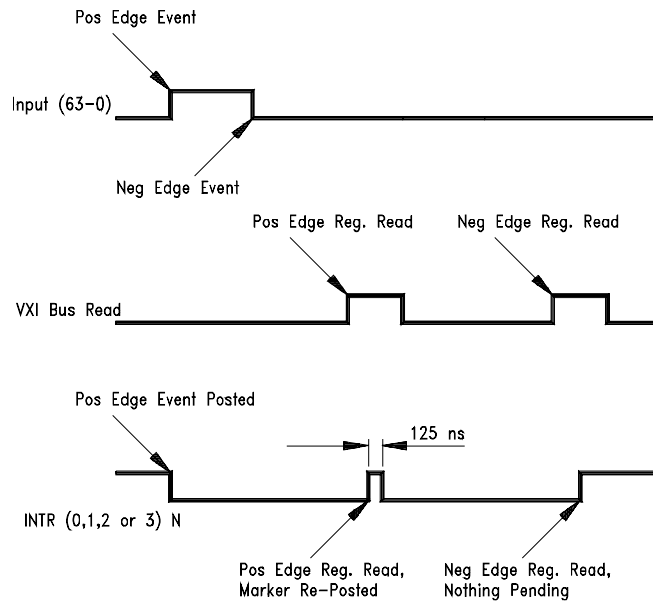

Figure 1-3. Positive and Negative Edge Transitions

In Figure 1-4, a channel that has been programmed for data capture posts a marker on the occurrence of an external capture clock. During the subsequent data register read cycle, another data capture clock occurs to create a pending DAV (Data Available) situation. The second DAV is retained (and valid) until a subsequent read of the corresponding data register.

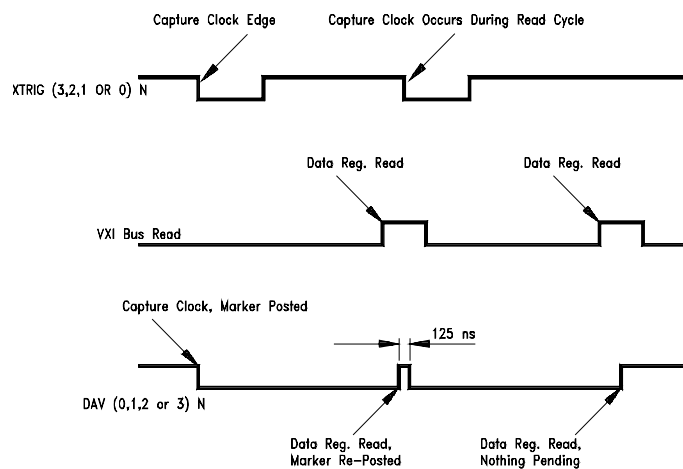

Figure 1-4. DAV Timing

Input Data Capture

The state of any channel, within any channel group, may be captured for subsequent processing (as data) by an externally sourced capture clock (XTRIG0N - XTRIG3N, the external trigger inputs for each port). Data channels may be interspersed among all 64 channel inputs, but the user is cautioned to ensure that all setup criteria and clock sources coincide with requirements for synchronization. (Each channel group shares a common capture clock which may not necessarily be synchronous with an external capture clock of some other channel group.)

If enabled, each register FPGA will post a "Data Available Marker" to the control FPGA on the occurrence of a corresponding capture clock. Data Available Markers are cleared by a read of the corresponding "Channel Data Register." (The static state of these markers may be tested via the "Data Available Register.") Capture clocks which occur concurrently with a "register read/marker clear" cycle, are queued and post-processed on completion of the present cycle. In that event, the marker bit is forced inactive for a two clock (16 MHz) period before again being posted to the control FPGA.

In the "Data Capture Mode", the Agilent E1459A may be programmed to generate an interrupt on the occurrence of an external capture clock, or an internal 1.0 MHz sample clock may be selected to allow the state of the data channels to be tested in the absence of a capture clock. Capture clock selection (internal/external) is controlled by bit 1 of the Command Register Word.

Caution A potential hazard exists if software were to improperly program the Agilent E1459A to post data-capture IRQ's with the internally selected 1.0 MHz clock source. In this situation, a DAV interrupt would be posted each microsecond (if software were able to service at that rate), and would cause software to continuously vector to interrupt service upon each "return from service." Therefore, the Agilent E1459A should never be programmed to generate DAV interrupts with the internal clock source selected.

In the Agilent E1459A the Data Ready Marker is guaranteed to be cleared when the clock source is switched from internal to external. Therefore, any capture clock which occurs within the internal/external clock selection interval will not post a marker to the control FPGA and will be lost.

Front Panel Markers

All "Data Available" and "Edge Detect" marker bits are physically available via the Agilent E1459A front panel. These outputs are TTL/HC compatible and may be used to trigger other system-wide events or to provide logging information for statistical tracking or other performance analysis purposes.

Interrupt Driven or Polled Mode Operations

Interrupts may be programmatically disabled for both edge-detect and data-capture events. All registers remain active and valid and may be serviced on a polled mode basis.

Interrupt Parsing

Since the command module interrupt handler must service multiple, concurrently-occurring interrupts, (including those which may be sharing the same IRQ line), some method is necessary to ensure that only a single IRQ is posted by the Agilent E1459A during each service interval.

Individual interrupts must be serviced by a commander on a one-for-one basis. The Agilent E1459A accomplishes this by inhibiting the generation of a second IRQ each time an IRQ is posted. **THE INHIBIT CONDITION IS CLEARED BY THE REMOVAL AND REASSERTION OF EITHER INTERRUPT ENABLE BIT, "DAV" OR "EDGE DETECT."** (Refer to Figure 1-2.)

For this one-for-one interrupt parsing, the Agilent E1459A **REQUIRES** that a global interrupt enable, either DAV or Edge Detect, be disabled and reasserted within the context of the interrupt service procedure. Normally, you would simply shut off interrupts at the top of the service procedure, and would then re-enable them before returning from service. This is the suggested usage, although this specific sequence is not necessary for proper Agilent E1459A hardware function.

Configuring for Installation

Before installing the module you should verify that the following jumpers and switches are set correctly.

- Logical Address dip switch
- Interrupt priority jumper positions
- Input threshold levels
- Reset time of the Watchdog Timer

WARNING **SHOCK HAZARD.** Only qualified, service-trained personnel who are aware of the hazards involved should install, configure, or remove the module. Disconnect all power sources from the mainframe, the terminal module and installed modules before installing or removing a module.

WARNING **SHOCK HAZARD.** When handling user wiring connected to the terminal module, consider the highest voltage present accessible on any terminal.

WARNING **SHOCK HAZARD.** Use wire with an insulation rating greater than the highest voltage which will be present on the terminal module. Do not touch any circuit element connected to the terminal module if any other connector to the terminal module is energized to more than 30 Vac RMS or 60 Vdc.

Caution **MAXIMUM VOLTAGE.** Maximum allowable voltage per channel for this module is 60 Vdc. Up to 115 Vdc or 115 Vac RMS can be applied from one channel to another or from any channel to chassis.

Caution **STATIC-SENSITIVE DEVICE.** Use anti-static procedures when removing, configuring, and installing a module. The module is susceptible to static discharges. Do not install the module without its metal shield attached.

Setting the Logical Address

Each module within the VXIbus mainframe must be set to a unique logical address. The setting is controlled by an 8 pin dip switch. This allows for values from 0 to 255. The factory setting of this switch is decimal 144. No two modules in the same mainframe can have the same logical address. The location is shown in Figure 1-5.

Setting the Interrupt Priority

At power on, after a SYSRESET, or after resetting the module via the control register, all masks will be cleared, interrupts will be disabled, and internal triggering will be enabled. With interrupts enabled, an interrupt will be generated whenever an edge occurs on a channel that has been enabled properly.

The interrupt priority jumper selects which priority level will be asserted. As shipped from the factory, the interrupt priority jumper should be in position 1. In most applications this should not be changed. When set to level X interrupts are disabled. The interrupt priority jumpers are identified on the sheet metal shield. A hole has been cut into the shield for access to the jumpers. Interrupts can also be disabled using the Control Register.

The jumper locations are shown in Figure 1-5. To change the setting, move the jumper or jumpers to the desired setting. If the card uses two 2-pin jumpers versus a single 4 pin jumper, the jumpers must all be placed in the same row for proper operation.

Note Consult your mainframe manual to be sure that backplane jumpers are configured correctly. If you are using the Agilent E1401B Mainframe these jumpers are automatically set when the card is installed.

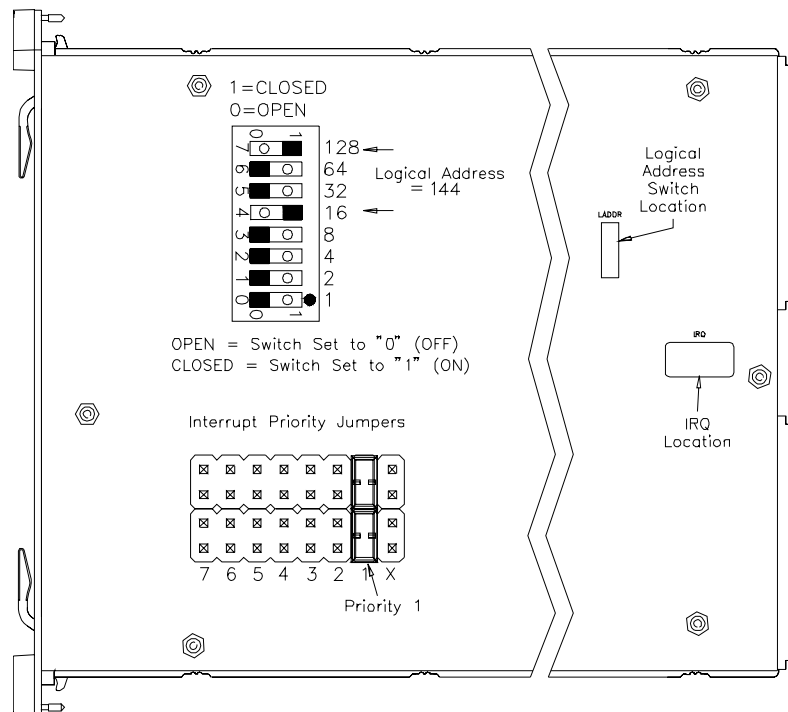

Figure 1-5. Agilent E1459A Logical Address Switch and IRQ Jumper Locations

Setting Input Threshold Levels

The threshold levels for each channel can be set independently. A six pin plug with a two pin shorting jack is provided for each channel. The channel can be identified from the silk-screen on the board. Each jumper is labeled JXCC, where J indicates jumper, X is a number that can be ignored and CC indicates channel number. The default factory setting is for 5 volts. Pin 1 can be identified by the square pad on the bottom of the board.

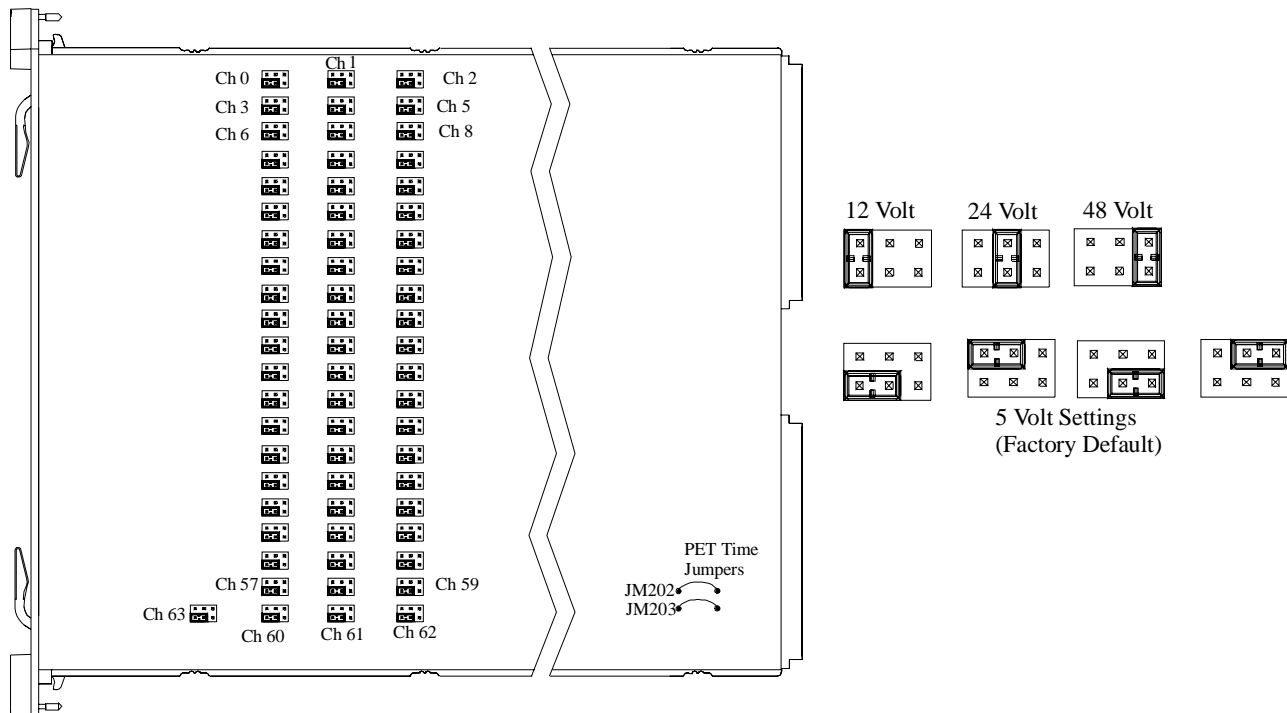

Figure 1-6. Input Threshold Level Jumpers and Watchdog Reset Time Jumpers

Setting the Reset Time on the Watchdog Timer

There are 2 jumpers located on the PC board used to control the reset time of the Watchdog Timer (see Figure 1-6). The reset time is the maximum allowed time between accesses to keep the Watchdog from asserting SYSRESET. The Watchdog timer is reset by reading the Watchdog Control/Status register; use the DIAG:SYSR:STAT? command (see Chapter 3).

The following table shows the effect of the jumpers on the reset time. An X means that the jumper is in place and O indicates the jumper is removed. The factory default setting is 1.2 second.

Jumper	Reset Time			
	600 ms	150 ms	1.2 sec	Not Allowed
JM202	O	X	O	X
JM203	O	O	X	X

Connecting User Inputs

The Agilent E1459A Isolated Digital Input/Interrupt module consists of a component module and a terminal block. User inputs for each channel consists of a low and a high connection for each channel. The inputs will only detect signals of a positive polarity. A logical "1" will only be detected if the high terminal is at a higher potential than the low terminal. It must also meet the drive requirements for the voltage threshold selected.

For each block of 16 channels an additional active low input and two active low outputs are available. The table below lists the signal names and the associated channels.

Port	Channels	External Trigger	Data Available	Interrupt
0	0 through 15	XTRIG0N	DAV0N	INTR0N
1	16 through 31	XTRIG1N	DAV1N	INTR1N
2	32 through 47	XTRIG2N	DAV2N	INTR2N
3	48 through 63	XTRIG3N	DAV3N	INTR3N

Figure 1-7 shows the front panel terminals and pinouts for the module. The cover to the terminal module is silk-screened to indicate the function of each screw terminal.

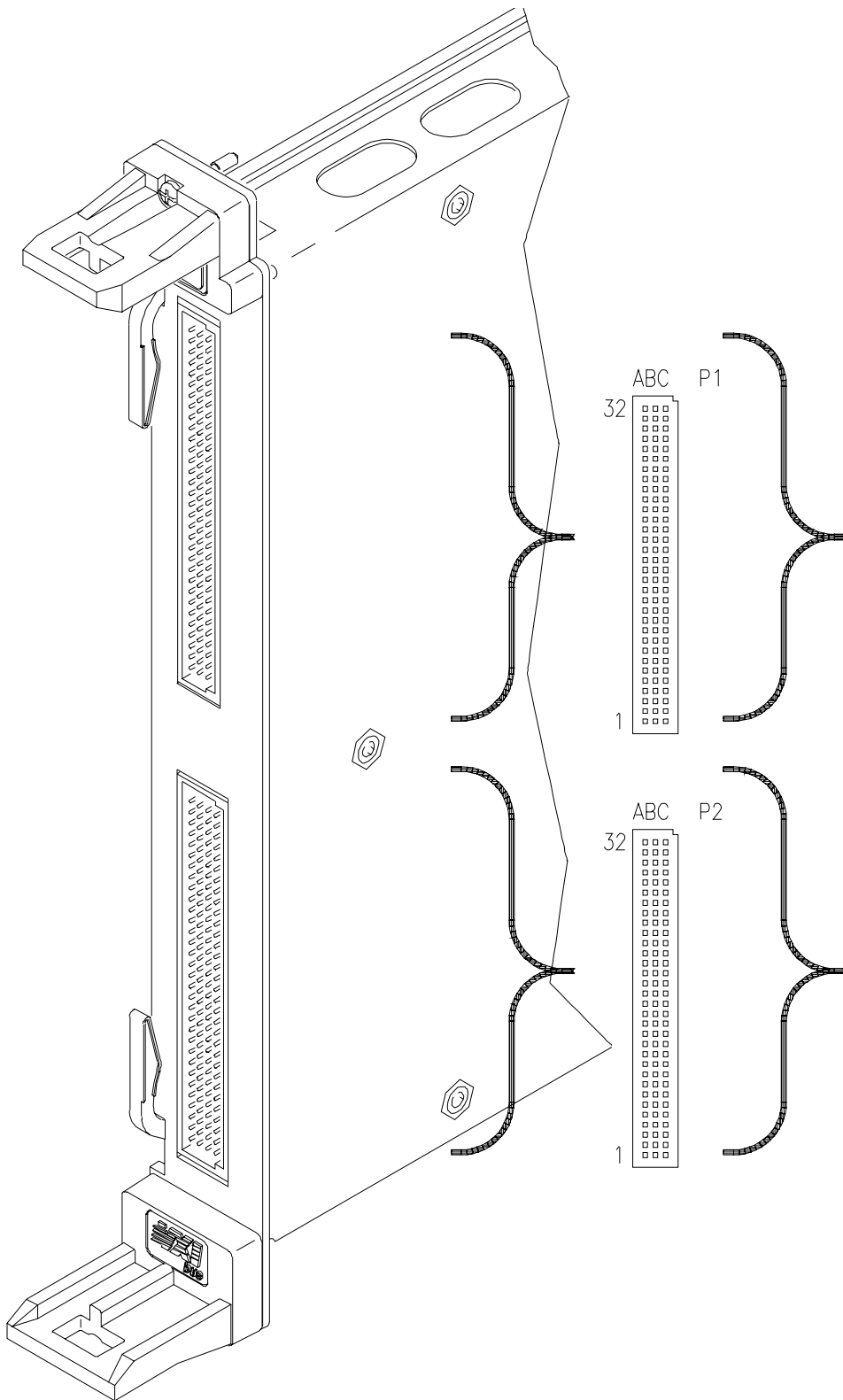

	A	B	C
32	CH 00 HI		CH 00 LO
31	CH 01 HI	CH 02 LO	CH 01 LO
30	CH 02 HI		CH 03 LO
29	CH 04 HI	CH 03 HI	CH 04 LO
28	CH 05 HI		CH 05 LO
27	CH 06 HI		CH 06 LO
26	CH 07 HI		CH 07 LO
25	CH 08 HI		CH 08 LO
24	CH 09 HI		CH 09 LO
23	CH 10 HI	CH 11 LO	CH 10 LO
22	CH 11 HI		CH 12 LO
21	CH 13 HI	CH 12 HI	CH 13 LO
20	CH 14 HI		CH 14 LO
19	CH 15 HI		CH 15 LO
18	CH 16 HI		CH 16 LO
17	CH 17 HI		CH 17 LO
16	CH 18 HI		CH 18 LO
15	CH 19 HI		CH 19 LO
14	CH 20 HI		CH 20 LO
13	CH 21 HI		CH 21 LO
12	CH 22 HI	CH 23 LO	CH 22 LO
11	CH 23 HI		CH 24 LO
10	CH 25 HI	CH 24 HI	CH 25 LO
9	CH 26 HI		CH 26 LO
8	CH 27 HI		CH 27 LO
7	CH 28 HI		CH 28 LO
6	CH 29 HI		CH 29 LO
5	CH 30 HI		CH 30 LO
4	CH 31 HI		CH 31 LO
3	CH 32 HI		CH 32 LO
2	CH 33 HI		CH 33 LO
1	CH 34 HI		CH 34 LO

	A	B	C
32	CH 35 HI		CH 35 LO
31	CH 36 HI	CH 37 LO	CH 36 LO
30	CH 37 HI		CH 38 LO
29	CH 38 HI	CH 39 HI	CH 39 LO
28	CH 40 HI		CH 40 LO
27	CH 41 HI	CH 42 LO	CH 41 LO
26	CH 42 HI		CH 43 LO
25	CH 43 HI	CH 44 HI	CH 44 LO
24	CH 45 HI		CH 45 LO
23	CH 46 HI		CH 46 LO
22	CH 47 HI		CH 47 LO
21	CH 48 HI		CH 48 LO
20	CH 49 HI		CH 49 LO
19	CH 50 HI		CH 50 LO
18	CH 51 HI		CH 51 LO
17	CH 52 HI		CH 52 LO
16	CH 53 HI		CH 53 LO
15	CH 54 HI	CH 55 LO	CH 54 LO
14	CH 55 HI		CH 56 LO
13	CH 56 HI	CH 57 HI	CH 57 LO
12	CH 58 HI		CH 58 LO
11	CH 59 HI		CH 59 LO
10	CH 60 HI	CH 61 LO	CH 60 LO
9	CH 61 HI		CH 62 LO
8	CH 62 HI	CH 63 HI	CH 63 LO
7			
6			
5	GND	+5VTC	GND
4	DAV3N	INTR3N	XTRIG3N
3	DAV2N	INTR2N	XTRIG2N
2	DAV1N	INTR1N	XTRIG1N
1	DAV0N	INTR0N	XTRIG0N

Figure 1-7. Front Panel Connections

Installing the Agilent E1459A in a VXIbus Mainframe

The Agilent E1459A may be installed in any C-size VXIbus mainframe slot (except slot 0). Refer to Figure 1-8 to install the module in a mainframe.

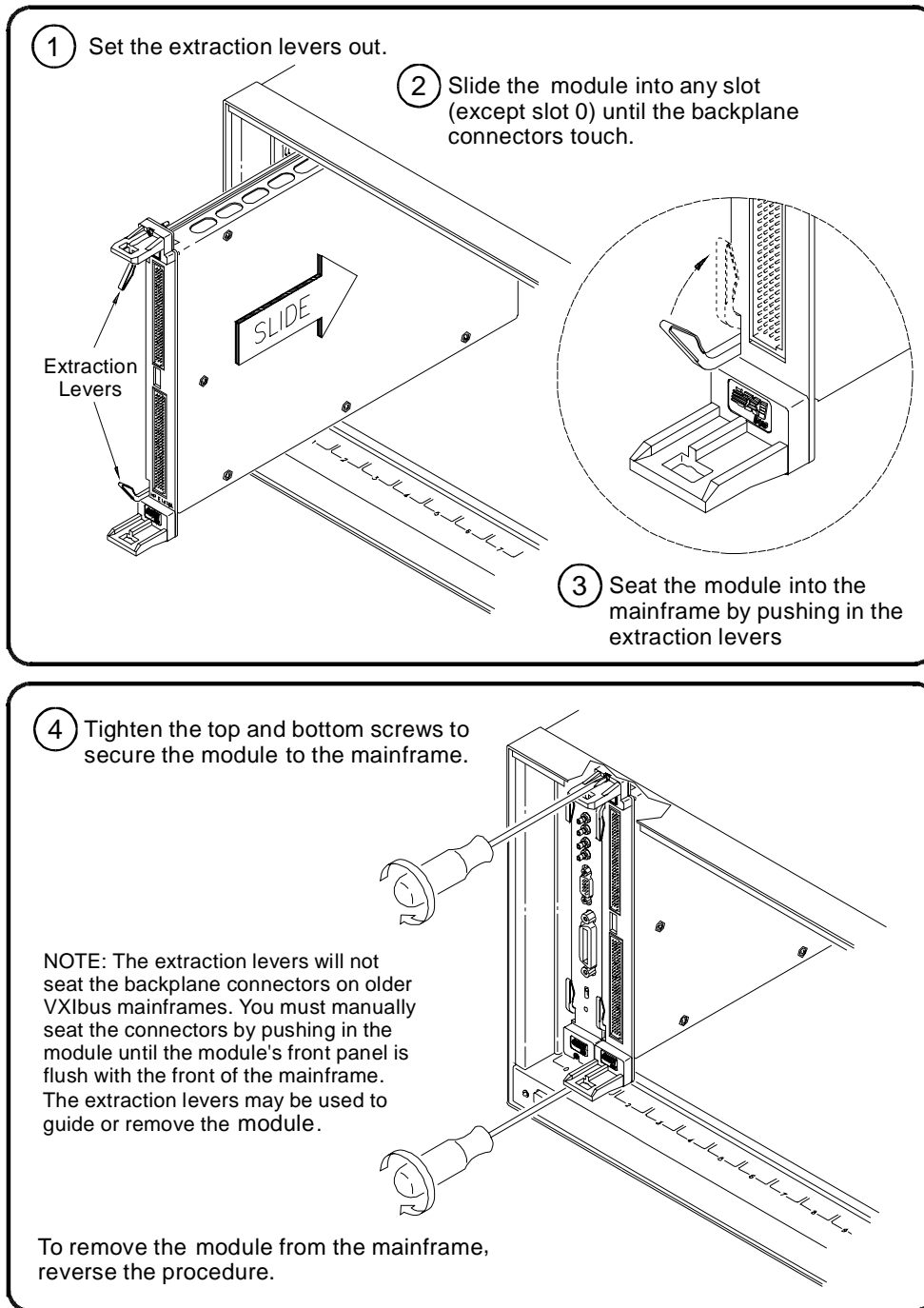

Figure 1-8. Installing the Agilent E1459A in a VXIbus Mainframe

WARNING To prevent electric shock, tighten faceplate screws when installing module into mainframe.

Terminal Block

The Agilent E1459A includes both the input / interrupt module and a screw-type standard terminal block. User inputs to the terminal block are to the High and Low for each channel, +5Volt, Ground, Data Valid (DAV0 - DAV3), External Trigger (XTRIG0 - XTRIG3), and Interrupt (INTR0 - INTR3) .

Figure 1-9 shows the Agilent E1459A's standard screw-type terminal block connectors and associated channel numbers. Use the guidelines below to wire connections.

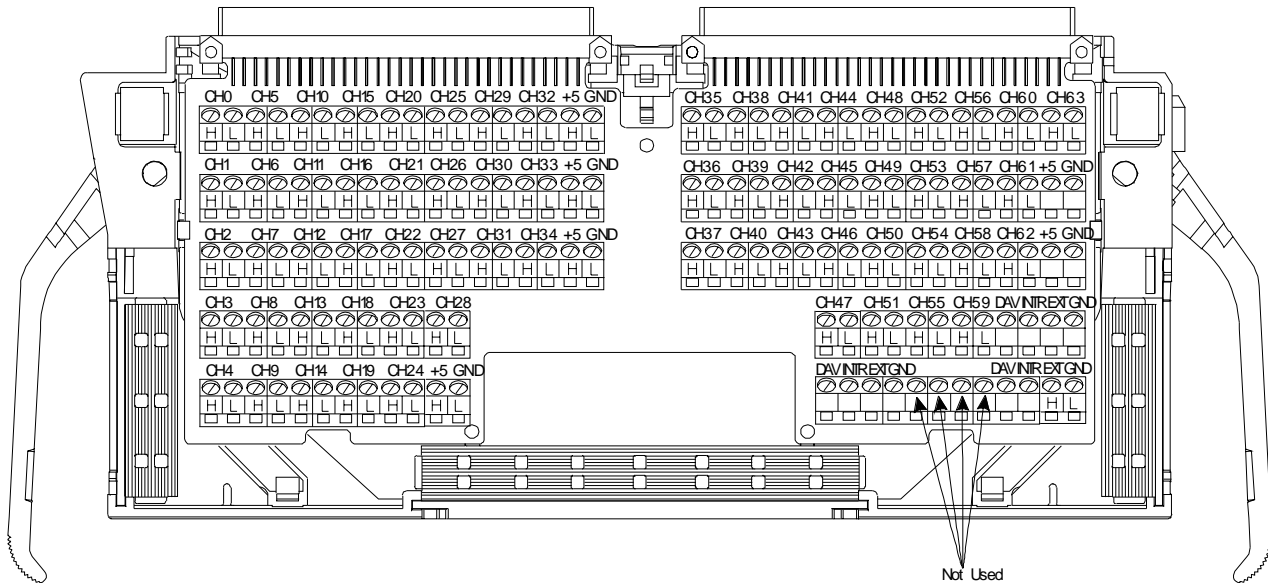

Figure 1-9. Agilent E1459A Standard Screw-type Terminal Block

Wiring Guidelines

- Be sure the wires make solid connections in the screw terminals.
- Maximum terminal wire size is No. 16 AWG. When wiring all channels, a smaller gauge wire (No. 20 or 22 AWG) is recommended. Wire ends should be stripped 5 to 6 mm (0.2 to 0.25 in.) and tinned to prevent single strands from shorting to adjacent terminals.

WARNING

To prevent the spread of fire in the case of a fault, use flame-rated field wiring whenever the input voltage will exceed 30Vrms, 42Vpeak, or 60Vdc.

Wiring a Terminal Block

The following illustrations show how to connect field wiring to the terminal block.

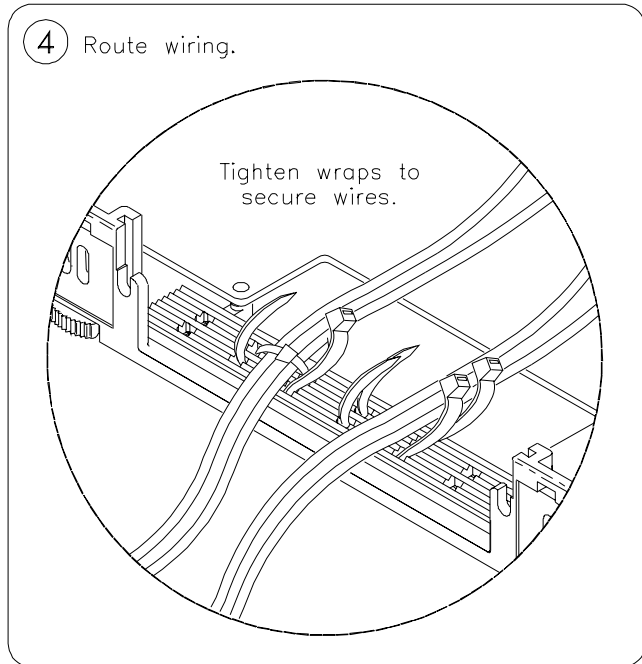
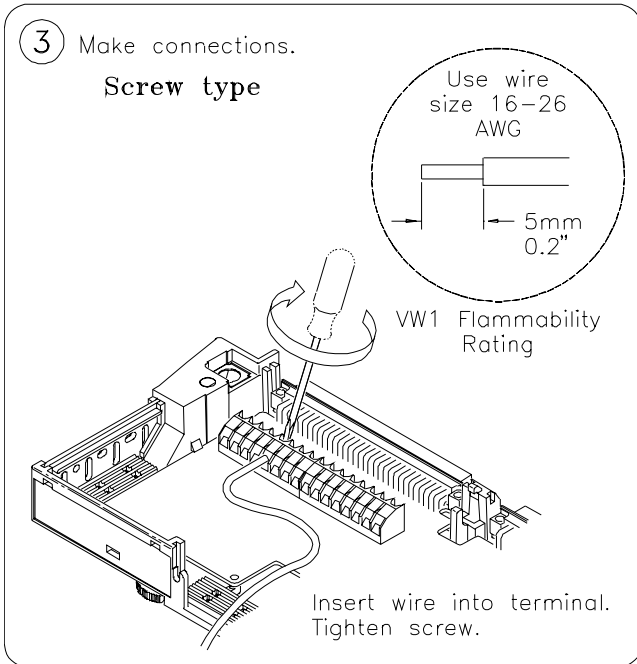
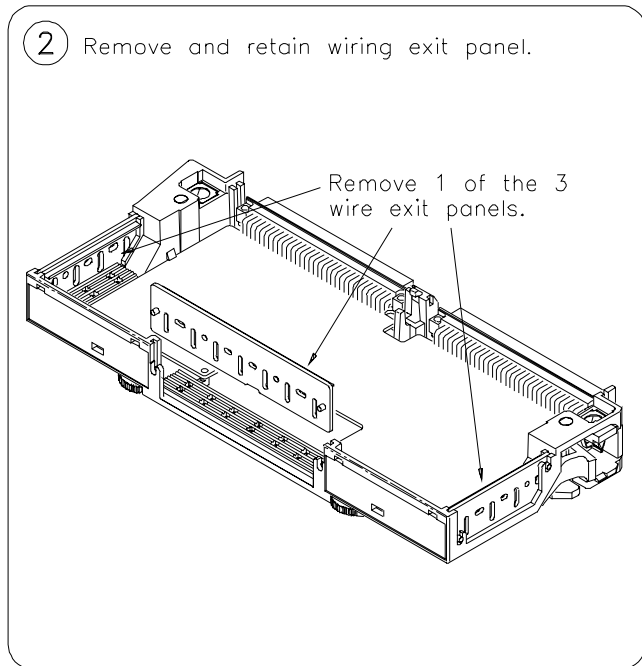
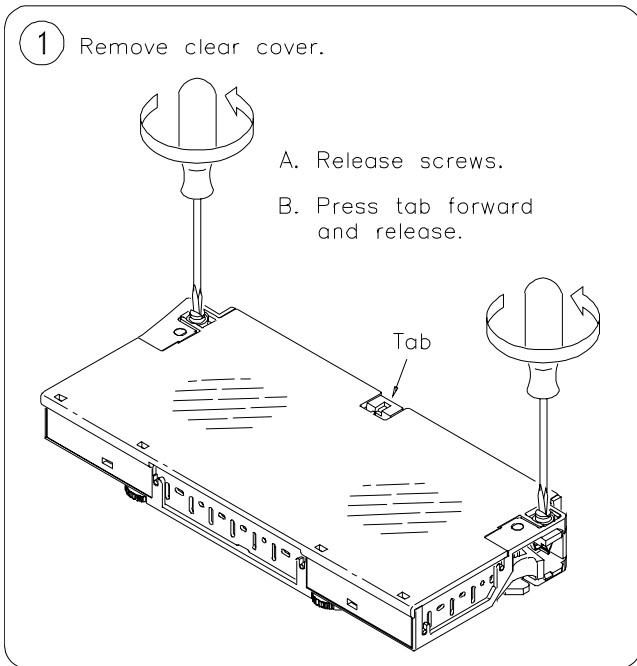

Continued on Next Page

5 Replace Wiring Exit Panel

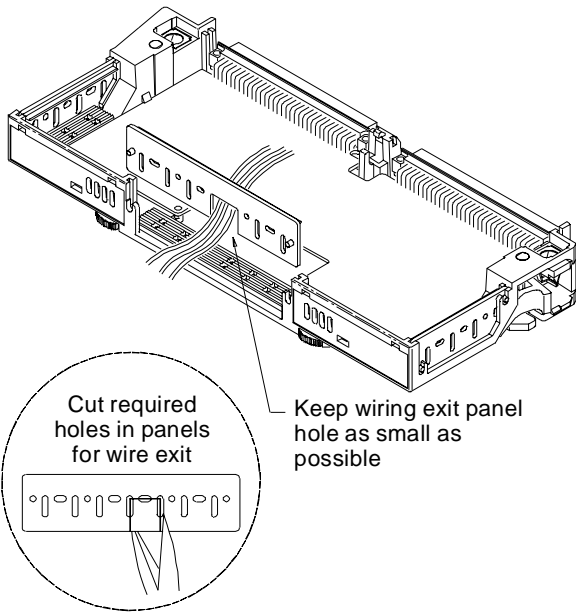

6 Replace Clear Cover

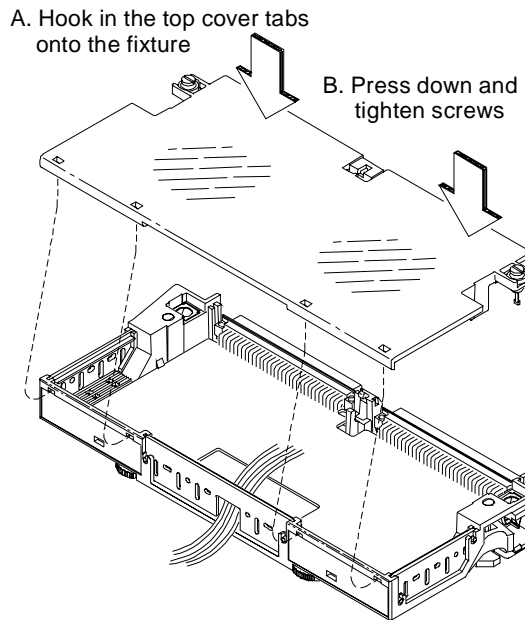

7 Install the Terminal Module

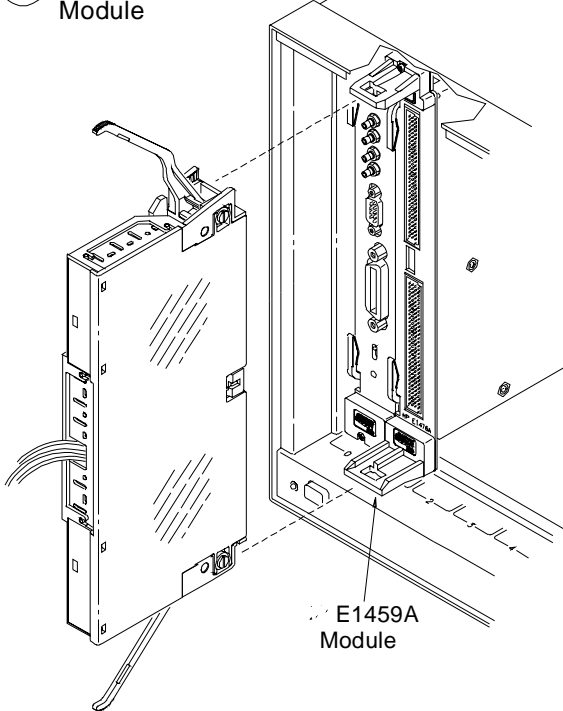

8 Push in the Extraction Levers to Lock the Terminal Module onto the E1459A

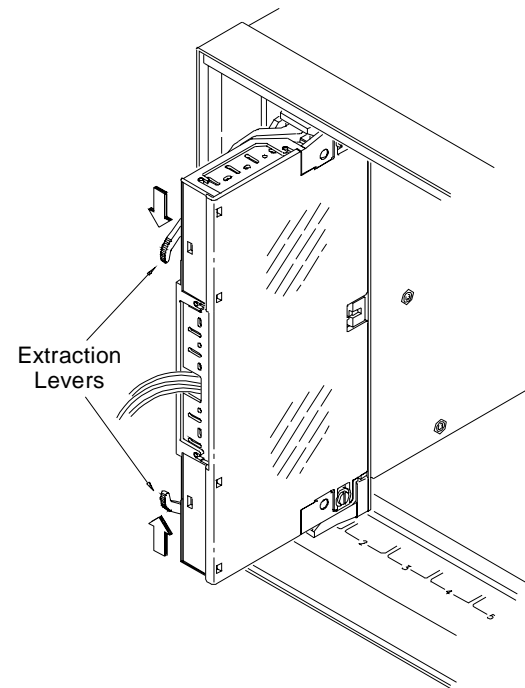

Chapter 2

Using the Agilent E1459A Module

This chapter provides examples of using and programming the Agilent E1459A using the Standard Commands for Programmable Instrumentation (SCPI). For detailed information on all the SCPI commands for this module, refer to Chapter 3. Appendix B in this manual provides information on registers and register-based programming.

Note If you are controlling the module by a high level language, such as the downloaded SCPI driver or the *VXIplug&play* driver, do not do register writes. This is because the high level driver will not know the instrument state and an interrupt may occur causing the driver and/or command module to fail.

The example programs in this chapter were developed with the ANSI C language using the Agilent VISA extensions. For additional information, refer to the *Agilent VISA User's Guide*. These programs were written and tested in Microsoft Visual C++ but should compile under any standard ANSI C compiler.

To run the programs you must have the Agilent SICL Library, the Agilent VISA extensions, and an Agilent 82340 or 82341 GPIB module installed and properly configured in your PC. An Agilent E1406 Command Module provides direct access to the VXI backplane.

Power-on / Reset States

At power-on or reset (*RST) the Agilent E1459A is set to the following conditions:

- Watchdog timer is off (disabled).
- Clock Source is Internal
- Input Debounce Time is 18.0 μ S.
- DAV (Data Available) Event interrupts are disabled for all ports.
- Edge Event interrupts are disabled for all ports.

Also, refer to the STATus:PRESet command in Chapter 3.

Example 1: Reset, Self Test, and Module ID

This first example resets the Agilent E1459A, performs the module self test, and reads the module ID and description.

```
/* Self Test
This program resets the Agilent E1459A, performs a Self Test,
and reads the ID string
Created in Microsoft Visual C++ */

#include <visa.h>
#include <stdio.h>
#include <stdlib.h>

#define INSTR_ADDR "GPIB0::9::3::INSTR" /* E1459A logical address */

int main()
{
ViStatus errStatus; /* status from VISA call */
ViSession viRM; /* Resource Mgr. session */
ViSession E1459; /* session for Agilent E1459A */

char id_string [256] = {0}; /* ID string buffer */
char selfst_string[256] = {0};

/* Open a default Resource Manager */
errStatus = viOpenDefaultRM (&viRM);
if (VI_SUCCESS > errStatus){
printf("ERROR: viOpen() returned 0x%x\n",errStatus);
return errStatus;}

/* Open the Instrument Session */
errStatus = viOpen (viRM, INSTR_ADDR,VI_NULL,VI_NULL, &E1459);
if (VI_SUCCESS > errStatus){
printf("ERROR: viOpen() returned 0x%x\n",errStatus);
return errStatus;}

/* Reset the E1459A */
errStatus = viPrintf (E1459, "**RST;*CLS\n");
if (VI_SUCCESS > errStatus){
printf("ERROR: viPrintf() returned 0x%x\n",errStatus);
return errStatus;}
```



```

/* Send the Self Test Command */
errStatus = viQueryf (E1459, "**TST?\n", "%t", selfst_string);
if (VI_SUCCESS > errStatus){
    printf("ERROR: viQueryf() returned 0x%x\n",errStatus);
    return errStatus;}
printf("Self Test Result is %s\n",selfst_string);

/* Query the ID string */
errStatus = viQueryf (E1459, "**IDN?\n", "%t", id_string);
if (VI_SUCCESS > errStatus){
    printf("ERROR: viQueryf() returned 0x%x\n",errStatus);
    return errStatus;}
printf("IDN? returned %s\n",id_string);

/* Close Sessions */
errStatus = viClose (E1459);
if (VI_SUCCESS > errStatus){
    printf("ERROR: viClose() returned 0x%x\n",errStatus);
    return 0;}

errStatusviClose (viRM);
if (VI_SUCCESS > errStatus){
    printf("ERROR: viClose() returned 0x%x\n",errStatus);
    return 0;}

}
/* End of main program */

```

Digital Input

The Agilent E1459A is capable of simple digital inputs on any of the individual four ports or combined Ports 0 and 1 or Ports 2 and 3. The MEASure command subsystem (see Chapter 3 for details) provides two commands for reading the current value of the input ports:

MEASure:DIGital:DATA:n: type:VALue? — reads the current port value

MEASure:DIGital:DATA:n: type:BITm? — reads an individual bit value

Example 2: Digital Input

This program reads Port 0 as an individual 16-bit port and then it reads the combined Ports 2 and 3 as a 32-bit port. The values returned are a signed 16-bit integer for Port 0 and a signed 32-bit integer for combined Ports 2 and 3. Although this program does not decode the returned value to determine individual bit/channel values, a "0" in any bit position indicates the input to the corresponding channel is low; a "1" in any bit position indicates the input to the corresponding channel is high.

```
/* Digital Input Example
   This program reads the current value of Port 0 (16-bit word)
   and combined value of Ports 2 and 3 (32-bit word)
   Created in Microsoft Visual C++ */

#include <visa.h>
#include <stdio.h>
#include <stdlib.h>

#define INSTR_ADDR "GPIB0::9::3::INSTR" /* E1459A logical address */

int main()
{
    ViStatus errStatus; /* status from VISA call */
    ViSession viRM; /* Resource Mgr. session */
    ViSession E1459; /* session for E1459A */
    int val; /* value of Port 0 */
    long val1; /* Value of Ports 2 & 3 */

    /* Open a default Resource Manager */
    errStatus = viOpenDefaultRM (&viRM);
    if (VI_SUCCESS > errStatus){
        printf("ERROR: viOpen() returned 0x%x\n",errStatus);
        return errStatus;}

    /* Open the Instrument Session */
    errStatus = viOpen (viRM, INSTR_ADDR,VI_NULL,VI_NULL, &E1459);
    if (VI_SUCCESS > errStatus){
        printf("ERROR: viOpen() returned 0x%x\n",errStatus);
        return errStatus;}

    /* Query Port 0 as a 16-bit word */
    errStatus = viQueryf(E1459, "MEAS:DIG:DATA0:WORD:VAL?%n", "%t", val);
    if (VI_SUCCESS > errStatus){
        printf("ERROR: viQueryf() returned 0x%x\n",errStatus);
        return errStatus;}
    printf("Value returned %i\n",val);
}
```

```

/* Query Ports 2 and 3 as a 32-bit word */
errStatus = viQueryf(E1459, "MEAS:DIG:DATA2:LWORD:VAL?\n", "%t", val1);
if (VI_SUCCESS > errStatus){
    printf("ERROR: viQueryf() returned 0x%x\n",errStatus);
    return errStatus;}
printf("Value returned %i\n",val1);

/* Close Sessions */
errStatus = viClose (E1459);
if (VI_SUCCESS > errStatus){
    printf("ERROR: viClose() returned 0x%x\n",errStatus);
    return 0;}

errStatus = viClose (viRM);
if (VI_SUCCESS > errStatus){
    printf("ERROR: viClose() returned 0x%x\n",errStatus);
    return 0;}

}
/* End of main program */

```

Edge Detected Event Detection

The Agilent E1459A can respond to two types of events: Edge Events (either negative edge, positive edge, or both) and Data Available. Figures 2-1 and 2-2 show the general flow of commands necessary to program the Agilent E1459A to detect events. Figure 2-1 shows the flow for Edge Event Detection, Figure 2-2 shows the flow for Data Available Event Detection.

Three general methods of identifying and servicing an Agilent E1459A detected event are:

- Polling the Port Summary Register
- Polling the VXI Status Subsystem
- SRQ Interrupt

When an Edge Event occurs, read the value of the port(s) with the [SENSE:]EVENT:PORTn:NEDGE? or [SENSE:]EVENT:PORTn:PEDGE? command. When a Data Available Event occurs, read the value of the port(s) with the MEASURE:DIGITAL:DATA command.

Polling the Port Summary Register

The first, and easiest method, is to repeatedly poll the Port Summary Register using either the SENSE:EVENT:PSUMMARY:EDGE? command (for Edge Events) or the SENSE:EVENT:PSUMMARY:DAVAILABLE? command (for Data Available Events) until an event occurs. Example 3 in this chapter demonstrates this procedure.

Polling the Status Subsystem

The second method is to set-up and repeatedly poll the Status Subsystem. You can poll the port summary condition register with the STATUS:OPERATION:PSUMMARY:CONDITION? command to determine when an event has occurred.

Alternately, set-up the port summary enable register to specify the type of event(s) and port(s) to monitor; use the STATUS:OPERATION:PSUMMARY:ENABLE<mask> command. Then enable bit 9 in the Status Operation Enable register; use the STATUS:OPERATION:ENABLE command. Repeatedly poll the module with the *STB? command to determine when bit 7 becomes set.

SRQ Interrupt

The third method is to set-up the Status Subsystem and have the Agilent E1459A Module interrupt (via SRQ) the system computer when an event occurs. In general, you must set-up the port summary enable register to specify the type of event(s) and port(s) to monitor; use the STATUS:OPERATION:PSUMMARY:ENABLE<mask> command. Then, enable bit 9 in the Status Operation Enable register; use the STATUS:OPERATION:ENABLE command. Enable the OPR bit (bit 7) in the Status Register with the *SRE 128 command; this allows the Operation Status register to generate the SRQ.

E1459A Edge Event Detection Flowchart

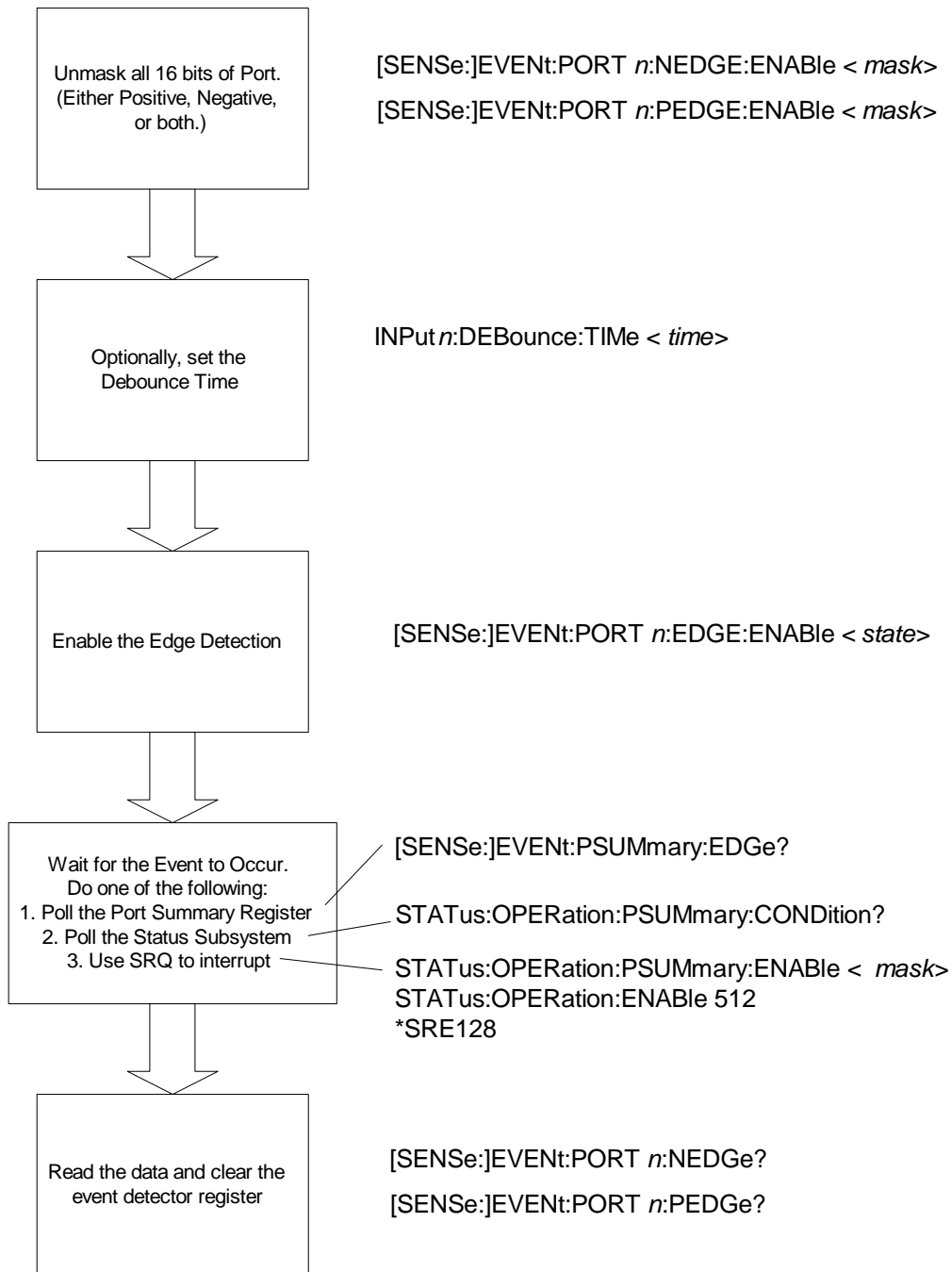

Figure 2-1. Agilent E1459A Edge Event Detection Flowchart

E1459A Data Available Event Detection Flowchart

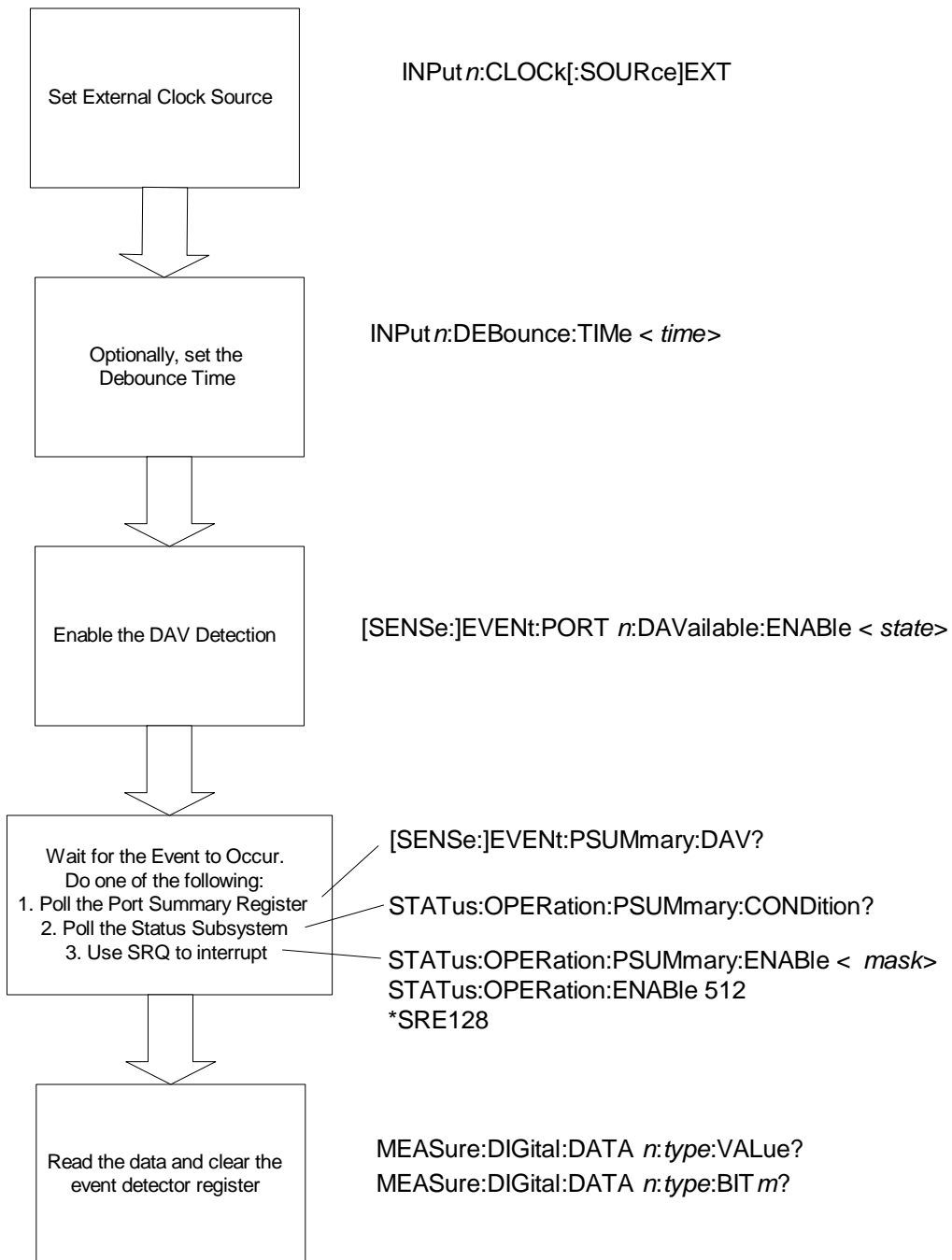

Figure 2-2. Agilent E1459A Data Available Event Detection Flowchart

Example 3: Edge Interrupt

This example repeatedly polls the Port 0 Port Summary Edge Detection Register to determine when an edge event occurs. When an event occurs, the program reads the values of the Positive and Negative Edge Registers and returns the values. The values returned are in the range of -32768 to +32767. Although this program does not decode this returned value to determine individual bit/channel values, a "0" in any bit position indicates an edge event was **not** detected for the corresponding channel; a "1" in any bit position indicates an edge event was detected for the corresponding channel.

/ Edge Interrupt Example*

This program sets both positive and negative edge detection, queries the Port Summary Edge Detection Register in a loop until an event occurs. The program then read the PEDGE and NEDGE registers and returns the current value.

*Created in Microsoft Visual C++ */*

```
#include <visa.h>
#include <stdio.h>
#include <stdlib.h>

#define INSTR_ADDR "GPIB0::9::3::INSTR" /* E1459A logical address */

int main()
{
    ViStatus errStatus; /* status from VISA call */
    ViSession viRM; /* Resource Mgr. session */
    ViSession E1459; /* session for Agilent E1459A */
    int val, event;

    /* Open a default Resource Manager */
    errStatus = viOpenDefaultRM (&viRM);
    if (VI_SUCCESS > errStatus){
        printf("ERROR: viOpen() returned 0x%x\n",errStatus);
        return errStatus;}

    /* Open the Instrument Session */
    errStatus = viOpen (viRM, INSTR_ADDR,VI_NULL,VI_NULL, &E1459);
    if (VI_SUCCESS > errStatus){
        printf("ERROR: viOpen() returned 0x%x\n",errStatus);
        return errStatus;}

    /* Unmask the negative edge events for Port 0 */
    errStatus = viPrintf (E1459, "EVEN:PORT0:NEDG:ENAB 0xFFFF\n");
    if (VI_SUCCESS > errStatus){
        printf("ERROR: viPrintf() returned 0x%x\n",errStatus);
        return errStatus;}

    /* Unmask the positive edge events for Port 0 */
    errStatus = viPrintf (E1459, "EVEN:PORT0:PEDG:ENAB 0xFFFF\n");
    if (VI_SUCCESS > errStatus){
        printf("ERROR: viPrintf() returned 0x%x\n",errStatus);
        return errStatus;}

    /* Set Port 0 debounce time to 1.13 mS */
    errStatus = viPrintf (E1459, "INP0:DEB:TIM 1E-3\n");
```

```

    if (VI_SUCCESS > errStatus){
        printf("ERROR: viPrintf() returned 0x%x\n",errStatus);
        return errStatus;}

    /* Enable Port 0 Edge Detection */
    errStatus = viPrintf (E1459, "EVEN:PORT0:EDGE:ENAB ON\n");
    if (VI_SUCCESS > errStatus){
        printf("ERROR: viPrintf() returned 0x%x\n",errStatus);
        return errStatus;}

    /* Loop and poll Port Summary Register until event occurs */
    while (event = 0)
    {
        errStatus = viQueryf (E1459, "EVEN:PSUM:EDGE?\n", "%t", event);
        if (VI_SUCCESS > errStatus){
            printf("ERROR: viPrintf() returned 0x%x\n",errStatus);
            return errStatus;}
        }

    /* Read NEDGE register and clear event detector register */
    errStatus = viQueryf (E1459, "EVEN:PORT0:NEDGE?\n", "%t", val);
    if (VI_SUCCESS > errStatus){
        printf("ERROR: viPrintf() returned 0x%x\n",errStatus);
        return errStatus;}
    printf ("Negative Edge Event value = %s\n",val);

    /* Read PEDGE register and clear event detector register */
    errStatus = viQueryf (E1459, "EVEN:PORT0:PEDGE?\n", "%t", val);
    if (VI_SUCCESS > errStatus){
        printf("ERROR: viPrintf() returned 0x%x\n",errStatus);
        return errStatus;}
    printf ("Positive Edge Event value = %s\n",val);

    /* Close Sessions */
    errStatus = viClose (E1459);
    if (VI_SUCCESS > errStatus){
        printf("ERROR: viClose() returned 0x%x\n",errStatus);
        return 0;}

    errStatus = viClose (viRM);
    if (VI_SUCCESS > errStatus){
        printf("ERROR: viClose() returned 0x%x\n",errStatus);
        return 0;}

}
/* End of main program */

```

Agilent E1459A SCPI Command Reference

The Standard Commands for Programmable Instruments (SCPI) commands described in this chapter are only available in the downloadable SCPI driver for the Agilent Command Modules such as the Agilent E1406. If you are not using a command module, you should use the Agilent *VXIplug&play* driver. This driver is available on the Agilent Instrument Drivers CD and available on the World Wide Web.

Common Command Format

The IEEE 488.2 standard defines the Common commands that perform functions like reset, self-test, status byte query, etc. Common commands are four or five characters in length, always begin with the asterisk character (*), and may include one or more parameters. The command keyword is separated from the first parameter by a space character. Some examples of common commands are shown below:

```
*RST *ESR 32 *STB?
```

SCPI Command Format

The SCPI commands perform functions such as making measurements, querying instrument states, or retrieving data. A command subsystem structure is a hierarchical structure that usually consists of a top level (or root) command, one or more low-level commands, and their parameters. The following example shows the root command DISPLAY and some of its lower-level subsystem commands:

```
:DISPlay
  :MONitor
    :PORT <port>
    :PORT? [MINimum | MAXimum | DEFault]
    [:STATe] <state>
    [:STATe]?
```

:DISPlay is the root command, :MONitor is a second level commands, and :PORT, PORT?, [:STATe], and [:STATe]? are third level commands.

Command Separator

A colon (:) always separates one command from the next lower level command:

```
DISPlay:MONitor:PORT <port>.
```

Colons separate the root command from the second level command (DISPlay:MONitor) and the second level from the third level (MONitor:CHANnel).

Abbreviated Commands

The command syntax shows most commands as a mixture of upper and lower case letters. The upper case letters indicate the abbreviated spelling for the command. For shorter program lines, send the abbreviated form. For better program readability, you may send the entire command. The instrument will accept either the abbreviated form or the entire command.

For example, if the command syntax shows DISPLAY, then DISP and DISPLAY are both acceptable forms. Other forms of DISPLAY, such as DISPL or DISPI will generate an error. You may use upper or lower case letters. Therefore, DISPLAY, display, and DiSpLaY are all acceptable.

Implied Commands

Implied commands are those which appear in square brackets ([]) in the command syntax. (Note that the brackets are not part of the command and are not sent to the instrument.) Suppose you send a command but do not send the associated implied command. In this case, the instrument assumes you intend to use the implied command and it responds as if you had sent it. For example:

DISPlay:MONitor[:STATe] <state>

The third level command [:STATe] is an implied command. For example, to set the display monitor state, you can send either of the following command statements:

DISPlay:MONitor <state> or DISPlay:MONitor:STATe <state>

Command Parameters

Parameter Types. The following table contains explanations and examples of parameter types you might see later in this chapter.

Parameter Type	Explanations and Example
Numeric	Accepts all commonly used decimal representations of number including optional signs, decimal points, and scientific notation. 123, 123E2, -123, -1.23E2, 0.123, 1.23E-2, 1.23000E-01. Special cases include MINimum, MAXimum, and DEFault.
Boolean	Represents a single binary condition that is either true or false. ON, OFF, 1, 0
Discrete	Selects from a finite number of values. These parameters use mnemonics to represent each valid setting. An example is the TRIGger:SOURce <source> command where source can be BUS, EXT, or IMM.

Optional Parameters. Parameters shown within square brackets ([]) are optional parameters. (Note that the brackets are not part of the command and are not sent to the instrument.) If you do not specify a value for an optional parameter, the instrument chooses a default value. For example, consider the :PORT? [MIN | MAX] command. If you send the command without specifying a MINimum or MAXimum parameter, the present PORT? value is returned. If you send the MIN parameter, the command returns the minimum current display channel. If you send the MAX parameter, the command returns the maximum display channel. Be sure to place a space between the command and the parameter.

Linking Commands

Linking IEEE 488.2 Common Commands with SCPI Commands. Use a semicolon between the commands. For example:

*RST;DISP:MON ON or DISP:MON ON;*TRG

Linking Multiple SCPI Commands. Use both a semicolon and a colon between the commands. For example:

DISP:MON:PORT 0::MEAS:DIG:DATA0:WORD::VAL?

DIAGnostic:SYSReset:ENABLE?

Returns the state of the Watchdog Timer as either a (unsigned) 1, or 0.

Parameters None

Comments Returns a 1 if the Watchdog Timer is enabled. Returns a 0 if the Timer is not enabled.

DISPlay:MONitor Subsystem

The DISPlay:MONitor subsystem turns on the monitor mode. Parameters related to the state of the data and control lines are shown on an external terminal¹. Refer to the Command Module's Users's Guide for supported terminal types. The DISPlay:MONitor commands do not apply to any C-SCPI or VXI*plug&play* driver implementation. The parameters displayed are:

Syntax	DISPlay:MONitor	
	:PORT <port>	page 43
	:PORT? [MINimum MAXimum DEFault]	page 44
	:PORT:AUTO <state>	page 44
	:PORT:AUTO?	page 44
	[:STATe] <state>	page 45
	[:STATe]?	page 45

DISPlay:MONitor:PORT <port>

Sets the value of the DISPlay:MONitor:PORT or sets the automatic display mode.

Parameters

Parameter Name	Parameter Type	Range of Values	Default
<port>	numeric or discrete	0, 1, 2, 3, AUTO, MINimum, MAXimum, DEFault	AUTO

Comments

- Sets the value of the Display Monitor to Port 0, 1, 2, or 3. AUTO automatically displays the results of a MEAS:DIG:DATA*n*? command whenever that command is executed for the monitored Port if the display monitor is active for the Port. MINimum or DEFault sets the value for the monitored Port to 0. MAXimum sets the value for the monitored Port to 3.
- Specifying either 0, 1, 2, 3, MIN, MAX, or DEF turns the AUTO mode off.
- ***RST Condition:** sets the display Port to 0 and the automatic display mode ON.

Example

DISP:MON:PORT2

Display data from port 2

DISP:MON:PORT AUTO

Set automatic display mode

1. The display monitor is an RS-232 Terminal attached to an Agilent E1405B, E1406, or E1306 Command Module and provides an interactive user interface to the Agilent E1459A.

DISPlay:MONitor:PORT? [MINimum | MAXimum | DEFault]

Returns the number of the current display Port as +0, +1, +2, or +3.

Parameters None

Comments

- When sent with no parameter, this query returns a decimal number indicating the Port being monitored. If AUTO was selected as the Port parameter in the DISP:MON:PORT <port> command, the query returns the number of the most recently-viewed Port. If either MINimum or DEFault was specified, this query returns a +0. If MAXimum was specified, this query returns a +3.

DISPlay:MONitor:PORT:AUTO <state>

Sets the automatic mode for the Display Monitor on or off. When AUTO mode is ON, the port being monitored is automatically set to the last last port measured.

Parameters

Parameter Name	Parameter Type	Range of Values	Default
<state>	numeric or discrete	0, 1, OFF, ON	OFF

Comments

- a 0 or OFF turns the display monitor automatic mode off; a 1 or ON turns the display monitor automatic mode on.
- ***RST Condition:** sets the automatic mode on.

Example DISP:MON:PORT:AUTO ON *Turns automatic display mode on*

DISPlay:MONitor:PORT:AUTO?

Returns the state of the automatic display mode as either +0 or +1.

Parameters None.

Comments

- A 0 indicates the automatic display mode is OFF; a 1 indicates the automatic display mode is ON.
- ***RST Condition:** sets the automatic mode on.

DISPlay:MONitor[:STATe] <state>

Turns the Display Mode on or off.

Parameters

Parameter Name	Parameter Type	Range of Values	Default
<state>	Numeric or discrete	0 1 OFF ON	OFF

Comments

- DISP:MON ON enables the terminal display of Port parameters. The parameters are updated to the terminal following each new command accessing a Port.
- The displayed data is in the format:
 - Displayed port number: 0, 1, 2, or 3
 - Size of the data: 16-bit word or 32-bit word
 - Actual data: signed decimal and hexadecimal
- A keyboard entry at the terminal sets DISP:MON OFF.
- ***RST Condition:** OFF.

Example

DISP:MON ON

turns the display mode on.

DISPlay:MONitor[:STATe]?

Returns the value of the Display Monitor State as either 0 (for OFF) or 1 (for ON).

Parameters

None

Comments

- DISP:MON[:STAT]? returns a 1 if the monitor mode is on; or returns a 0 if the monitor mode is off.

Example

DISP:MON?

INPutn:CLOCK[:SOURce]?

Returns the programmed value of the input clock source for Port *n*.

Parameters

Parameter Name	Parameter Type	Range of Values	Default
INPutn	numeric	0, 1, 2, 3	0

Comments • The value returned is an unquoted string of **EXT** or **INT**.

Example INPut2:CLOCK[:SOURce]? *queries the input clock source for Port 2.*

INPutn:DEBounce:TIME <time> | MINimum | MAXimum | DEFault

Programs the input debounce time for Port *n*. Ports 0 and 1 share the same debounce circuitry; Ports 2 and 3 share the same debounce circuitry.

Parameters

Parameter Name	Parameter Type	Range of Values	Default
INPutn	numeric	0, 1, 2, 3	0
<time>	numeric (floating pt)	18.0 μ Sec through 9600 Sec	18.0 μ Sec
DEFault		Default 18.0 μ Sec	
MINimum		Minimum 18.0 μ Sec	
MAXimum		Maximum 9600 Sec	

Comments

- The available debounce times are:
18.0 μ S, 36 μ S, 72 μ S, 144 μ S, 288 μ S, 576 μ S, 1.13 mS, 2.26 mS, 4.6 mS, 9.2 mS, 18.4 mS, 36.9 mS, 73.8 mS, 148.0 mS, 294.0 mS, 590.0 mS, 1.18 S, 2.36 S, 4.72 S, 9.43 S, 18.9 S, 37.8 S, 75.0 S, 150.0 S, 300 S, 600 S, 1200 S, 2400 S, 4800 S, 9600 S. Any value sent other than those listed is rounded to the nearest discrete value.
- Debounce time is rounded to the nearest discrete value. For example 16.0 μ S to 18.4 μ S is rounded to 18 μ S, 18.5 μ S to 36.4 μ S is rounded to 36 μ S, 36.5 μ S to 72.4 μ S is rounded to 72 μ S, etc.
- Ports 0 and 1 use the same debounce time, Ports 2 and 3 use the same debounce time. For *n* = 0 or *n* = 1, both Ports 0 and 1 are set; for *n* = 2 or *n* = 3, both Ports 2 and 3 are set.
- ***RST Condition:** sets the value for the debounce time to 18.0 μ Sec for all four Ports.

INPut n :DEBounce:TIME? [MINimum | MAXimum | DEFault]

Returns the current debounce time for Port n as a floating point number formatted as +d.dddddE±ddd

Parameters

Parameter Name	Parameter Type	Range of Values	Default
INPut n	numeric	0, 1, 2, 3	0
<time>	numeric (floating pt)	18.0 μ sec through 9600 sec	18.0 μ sec
DEFault		Default 18.0 μ sec	
MINimum		Minimum 18.0 μ sec	
MAXimum		Maximum 9600 sec	

Comments

- Ports 0 and 1 use the same debounce time, Ports 2 and 3 use the same debounce time. For $n = 0$ or $n = 1$, this command returns the debounce time for both Ports 0 and 1; for $n = 2$ or $n = 3$, this command returns the debounce time for both Ports both Ports 2 and 3.

Example

INP2:DEB:TIME?

Queries input circuit debounce time of Port 2

The MEASure commands are used for the Isolated Digital Input part of the Agilent E1459A. These commands return data corresponding to the current value of the input signals. Refer to Chapter 2 for more examples of using the MEASure Subsystem.

Syntax MEASure:DIgital:DATA n [:*type*][:VALue]?
:DIgital:DATA n [:*type*]:BIT m ?

page 49
page 50

MEASure:DIgital:DATA n [:*type*] [:VALue]?

Returns the current data for the specified Port n as a signed integer.

Parameters

Parameter Name	Parameter Type	Range of Values	Default
DATA n	Numeric	0, 1, 2, 3 for type WORD; 0, 2 for LWORD	0
TYPE	discrete	WORD (Ports 0, 1, 2, or 3) LWORD (for Ports 0 or 2)	WORD

Comments

- For *TYPE* WORD, the data is returned as a signed 16 bit integer. Example values returned include: +0, +1, +32767, -32768. Specify port as either DATA0, DATA1, DATA2, or DATA3.
- For *TYPE* LWORD, the data is returned as a signed 32 bit integer with Port 0 or Port 2 in the least significant bytes. Specify port as DATA0 or DATA2.
- Default is Port 0. :DATA is equivalent to :DATA0.

Example MEAS:DIg:DATA 1:WORD:VAL?

Queries 16-bit data from Port 1

MEAS:DIg:DATA 0:LWORD:VAL?

Queries 32-bit word from Ports 0 and 1

MEASure:DIGital:DATA n [:type]:BIT m ?

Returns the value of BIT m of the data for the specified Port n as a signed integer of either +0 or +1.

Parameters

Parameter Name	Parameter Type	Range of Values	Default
DATA n	Numeric	0, 1, 2, or 3 for WORD; 0 or 2 for LWORd	
TYPE	discrete	WORD (Ports 0, 1, 2, 3) LWORd (for Ports 0 or 2)	Word
BIT m	Numeric	0 - 15 for WORD, 0 - 31 for LWORd	none

Comments

- For *TYPE* LWORd, the data from the Channel Data registers for Ports 0 and 1 OR Ports 2 and 3 are combined as a single 32 bit integer. Port 0 is the least significant bits such that bit 0 of Port 0 becomes bit 0 and bit 15 of Port 1 becomes bit 31 of the 32 bit integer. Likewise, Port 2 is the least significant bits such that bit 0 of Port 2 becomes bit 0 and bit 15 of Port 3 becomes bit 31 of the 32 bit integer. The specified Port must be DATA0 or DATA2. Refer to Chapter 2 for more details.
- ***RST Condition:** sets the input clock source to INTernal and the debounce time to 18.0 μ S.

Example

MEAS:DIG:DATA3:WORD:BIT 12?

Queries value of Bit 12 in 16-bit word from Port 3

MEAS:DIG:DATA 2:LWORD:BIT23?

Queries value of Bit 23 in 32-bit word from Ports 2 and 3 (Bit 7 in Port 3)

This command accesses the SCPI memory subsystem.

MEMory:DELete:MACRo <name>

Deletes the MACRO command defined by the name <name>.

Parameters

Parameter Name	Parameter Type	Range of Values	Default
<name>	discrete	up to 12 alphanumeric characters	None

Comments

- The macro was previously defined using the *DMC Common Command.
- The maximum length for <name> is 12 characters.
- This command deletes the single, named macro; the *PMC Common command purges all macros.

Example

MEM:DEL:MACR test_macro

*Deletes the macro named test_macro which was previously defined using the *DMC Common command.*

The SENSe Subsystem configures Event Detection in the Agilent E1459A Module. The Agilent E1459A has an event detector for each 16 bit Port to detect positive or negative edge transitions and whether new data is available:

- DAV** New data is available on the specified digital input port(s).
- NEDGe** Negative Edge transition occurred on a specified digital input channel(s).
- PEDGe** Positive Edge transition occurred on a specified digital input channel(s).

For details on using the SENSe Subsystem, refer to Chapter 2.

Syntax	[SENSe:]EVENT	
	:PORTn:DAVailable?	page 52
	:PORTn:DAVailable:ENABLE <state>	page 53
	:PORTn:DAVailable:ENABLE?	page 53
	:PORTn:EDGE?	page 54
	:PORTn:EDGE:ENABLE <state>	page 54
	:PORT:EDGE:ENABLE?	page 55
	:PORTn:NEDG?	page 55
	:PORTn:NEDG:ENABLE <mask>	page 56
	:PORTn:NEDG:ENABLE?	page 56
	:PORTn:PEDG?	page 57
	:PORTn:PEDG:ENABLE <mask>	page 57
:PORTn:PEDG:ENABLE?	page 58	
:PSUMmary:DAVailable?	page 58	
:PSUMmary:EDGE?	page 59	

[SENSe:]EVENT:PORTn:DAVailable?

Returns the status of the DAVailable Event for Port *n* as either a (unsigned) 0 or a 1.

Parameters

Parameter Name	Parameter Type	Range of Values	Default
PORTn	numeric	0, 1, 2, 3 (PORT = PORT0)	PORT0

Comments

- 1 indicates the event did occur; 0 indicates the event did not occur.
- The event must be enabled using the [SENS:]EVEN:PORTn:DAV:ENAB command.
- The event is cleared by reading the data on Port *n* with the MEAS:DIG:DATA n ? command.

Example	SENS:EVEN:PORT 2:DAV?	<i>Returns status of DAV Event for Port 2</i>
	EVEN:PORT 1:DAV?	<i>Returns status of DAV Event for Port 1</i>

[SENSE:]EVENT:PORT n :DAVailable:ENABLE <state>

Enables a Data Available interrupt to occur when new data is latched into Port n by an external clock source.

Parameters

Parameter Name	Parameter Type	Range of Values	Default
PORT n	numeric	0, 1, 2, 3 (PORT = PORT0)	PORT0
<state>	numeric or discrete	0, 1, OFF, ON	OFF

Comments

- The clock source for Port n must be set to EXTERNAL and the event must be enabled. Otherwise, error -221, "Settings conflict" occurs.
- The external clock source is selected with the INPUT n :CLOCK[:SOURCE]EXT command.
- ***RST Condition:** disables the interrupt.

Example

EVEN:PORT 1:DAV:ENAB ON

Enables DAV on Port 1

[SENSE:]EVENT:PORT n :DAVailable:ENABLE?

Returns the state of the DAVailable Event Enable for Port n as either a (unsigned) 0 or a 1.

Parameters

Parameter Name	Parameter Type	Range of Values	Default
PORT n	numeric	0, 1, 2, 3 (PORT = PORT0)	PORT0

Comments

- A 0 means the DAVailable Event is disabled, 1 means it is enabled.
- ***RST Condition:** disables the interrupt.

[SENSE:]EVENT:PORT n :EDGE?

Returns the status of the Edge Detect Event for Port n as either a (unsigned) 0 or a 1.

Parameters

Parameter Name	Parameter Type	Range of Values	Default
PORT n	numeric	0, 1, 2, 3 (PORT = PORT0)	PORT0

Comments

- A 0 means an edge event was not detected; a 1 means an edge event was detected.
- An edge event must have been enabled by the [SENSE:]EVENT:PORT n :EDGE<state> command and a Positive edge mask and/or Negative edge mask must be enabled and set to a non-zero value.
- The Edge Event Status is cleared by reading PEDGE and/or NEDGE status registers for that port.

[SENSE:]EVENT:PORT n :EDGE:ENABLE <state>

Enables / disables an edge event interrupt for Port n .

Parameters

Parameter Name	Parameter Type	Range of Values	Default
PORT n	numeric	0, 1, 2, 3 (PORT = PORT0)	PORT0
<state>	numeric or discrete	0, 1, OFF, ON	OFF

Comments

- Refer to the [SENSE:]EVENT:PORT n :PEDGe:ENAB or [SENSE:]EVENT:PORT n :NEDGe:ENAB commands to configure the edge detect registers.
- The Edge Event Status is cleared by reading PEDGE and/or NEDGE status registers for that port.
- ***RST Condition:** not enabled.

Example

EVEN:PORT 2:EDGE:ENAB ON

Enables Edge Detection on Port 2

[SENSE:]EVENT:PORT*n*:EDGE:ENABLE?

Returns the state of the Edge Event Enable for Port *n* as a (unsigned) 0 or a 1.

Parameters

Parameter Name	Parameter Type	Range of Values	Default
PORT <i>n</i>	numeric	0, 1, 2, 3 (PORT = PORT0)	PORT0

- Comments**
- A 0 means the Edge Event is not enabled; a 1 means it is enabled.

[SENSE:]EVENT:PORT*n*:NEDGE?

Returns the value of the Negative Edge Detect Register for all 16 bits of Port *n*.

Parameters

Parameter Name	Parameter Type	Range of Values	Default
PORT <i>n</i>	numeric	0, 1, 2, 3 (PORT = PORT0)	PORT0

- Comments**
- The value returned is in the range of -32768 to +32767. A 0 in any bit position indicates a negative edge event was **not** detected for the corresponding bit of that port; a 1 in any bit position indicates a negative edge event was detected for the corresponding bit of that port.
 - When an edge event is detected, the Edge Detect Status is set true. Refer to the [SENSE:]EVENT:PSUM:EDGE? and [SENSE:]EVENT:PORT*n*:EDGE? commands.
 - Reading this register for all events that have occurred will clear the event detector register.
 - ***RST Condition:** disables the Edge Event.

[SENSe:]EVENT:PORT n :NEDGE:ENABLE <mask>

Sets the Negative Edge Detection Mask for Port n .

Parameters

Parameter Name	Parameter Type	Range of Values	Default
PORT n	numeric	0, 1, 2, 3 (PORT = PORT0)	PORT0
<mask>	numeric	-32768 to +32767 (0000 _h to FFFF _h)	0

Comments

- Each bit enables the corresponding channel negative edge detect for Port n . A 1 means the mask is enabled for that bit, a 0 means the mask is disabled for that bit.
- ***RST Condition:** clears the mask (no enabled bits).

Example

EVEN:PORT 1:NEDGE:ENAB 32767

Enables Negative Edge Event Detection on all bits of Port 1

[SENSe:]EVENT:PORT n :NEDGE:ENABLE?

Returns the decimal value of the Negative Edge Detection Mask as a 16 bit integer.

Parameters

Parameter Name	Parameter Type	Range of Values	Default
PORT n	numeric	0, 1, 2, 3 (PORT = PORT0)	PORT0

Comments

- Returns a number in the range of -32768 to +32767.
- Each bit enables the corresponding channel negative edge detect mask for Port n . A 1 means the mask is enabled for that bit, a 0 means the mask is disabled for that bit.
- ***RST Condition:** clears the mask (no masked bits).

[SENSE:]EVENT:PORT n :PEDGe?

Returns the value of the Positive Edge Detect Register for all 16 bits of Port n .

Parameters

Parameter Name	Parameter Type	Range of Values	Default
PORT n	numeric	0, 1, 2, 3 (PORT = PORT0)	PORT0

Comments

- The value returned is in the range of -32768 to +32767. A 0 in any bit position indicates a positive edge event was **not** detected for the corresponding bit of that port; a 1 in any bit position indicates a positive edge event was detected for the corresponding bit of that port.
- When an edge event is detected, the Edge Detect Status is set true. Refer to the [SENSE:]EVENT:PSUM:EDGE? and [SENSE:]EVENT:PORT n :EDGE? commands.
- Reading this register for all events that have occurred will clear the event detector register.
- ***RST Condition:** disables the Edge Event.

[SENSE:]EVENT:PORT n :PEDGe:ENABLE <mask>

Sets the Positive Edge Detection Mask for Port n .

Parameters

Parameter Name	Parameter Type	Range of Values	Default
PORT n	numeric	0, 1, 2, 3 (PORT = PORT0)	PORT0
<mask>	numeric	-32768 to +32767 (0000 _h to FFFF _h)	0

Comments

- Each bit enables the corresponding channel positive edge detect mask for Port n . A 1 means the mask is enabled for that bit, a 0 means the mask is disabled for that bit.
- ***RST Condition:** clears the mask (no enabled bits).

Example

EVEN:PORT 1:PEDG:ENAB 32767

Enables Positive Edge Event Detection on all bits of Port 1

[SENSE:]EVENT:PORT*n*:PEDGe:ENABLE?

Returns the decimal value of the Positive Edge Detection Mask as a 16 bit integer.

Parameters

Parameter Name	Parameter Type	Range of Values	Default
PORT <i>n</i>	numeric	0, 1, 2, 3 (PORT = PORT0)	PORT0

Comments

- Returns a number in the range of -32768 to +32767.
- Each bit enables the corresponding channel positive edge detect mask for Port *n*. A 1 means the mask is enabled for that bit, a 0 means the mask is disabled for that bit.
- ***RST Condition:** clears the mask (no enabled bits).

[SENSE:]EVENT:PSUMmary:DAVailable?

Returns the status of the DAVailable Event for ALL ports as a 16 bit integer.

Parameters None

Comments

- The value returned is in the range of +0 to +15 and is the sum of the following values:

Value Returned	Meaning
0	No Event occurred in any port
1	A DAV event occurred in Port 0
2	A DAV event occurred in Port 1
4	A DAV event occurred in Port 2
8	A DAV event occurred in Port 3

- This command is similar to the [SENSE:]EVENT:PORT*n*:DAV? command except that this command returns the status for all ports.

Example If the EVEN:PSUM:DAV? command returns a value of 5 it indicates a DAV event occurred on Ports 0 and 2 (values 1 and 4 respectively, see table).

[SENSE:]EVENT:PSUMmary:EDGE?

Returns the status of the edge events for ALL ports.

Parameters None

Comments

- The value returned is in the range of +0 to +15 and is the sum of the following values:

Value Returned	Meaning
0	No Edge Event occurred in any port
1	An Edge event occurred in Port 0
2	An Edge vent occurred in Port 1
4	An Edge vent occurred in Port 2
8	An Edge vent occurred in Port 3

- This command is similar to the [SENSE:]EVENT:PORTn:EDGE? command except that this command returns the status for all ports.

Example If the EVEN:PSUM:EDGE? command returns a value of 10 it indicates an edge event occurred on Ports 1 and 3 (values 2 and 8 respectively, see table).

STATus Subsystem

The STATus subsystem controls the SCPI-defined Operation and Questionable Status registers, Standard Event register, and the Status Byte register. Each is comprised of a condition register, an event register, an enable mask, and transition filters.

Note Transition filters are always set for positive edge transitions. When an event occurs, the condition is set and the event register bit is set true. If the event condition is cleared, the event status register remains set. The event status register is cleared upon reading that register.

Each status register works as follows: when a condition occurs, the appropriate bit in the condition register is set or cleared. The contents of the events register and the enable mask are logically ANDed bit-for-bit; if any bit of the result is set, the summary bit for that register is set in the status byte. The status byte summary bit for the Operation status register is bit 7; for the Questionable Signal status register, bit 3; and for the Standard Event registers is bit 5.

Syntax	STATus	
	:OPERation	
	:CONDition?	page 62
	:ENABle <mask>	page 62
	:ENABle?	page 63
	[:EVENT]?	page 63
	:PSUMmary:CONDition?	page 63
	:PSUMmary:ENABle <mask>	page 64
	:PSUMmary:ENABle?	page 64
	:PSUMmary[:EVENT]?	page 65
	:PRESet	page 65
	:QUESTionable	
	:CONDition?	page 66
	:ENABle <mask>	page 66
	:ENABle?	page 67
[:EVENT]?	page 67	

The STATus system contains five registers, two of which are under IEEE 488.2 control: the Event Status Register (*ESE?) and the Status Byte Register (*STB?). The Operational Status bit (OPR), Service Request bit (RQS), Event Summary bit (ESB), Message Available bit (MAV) and Questionable Data bit (QUE) in the Status Byte Register (bits 7, 6, 5, 4 and 3 respectively) can be queried with the *STB? command. Use the *ESE? command to query the *unmask* value for the Event Status Register (the bits you want logically "OR'd" into the Summary bit). The registers are queried using decimal weighted bit values. The decimal equivalents for bits 0 through 15 are included in Figure 3-1.

Note The Questionable Status Condition, Event, and Enable registers exist for SCPI compliance only. No status bits are defined or reported in these registers.

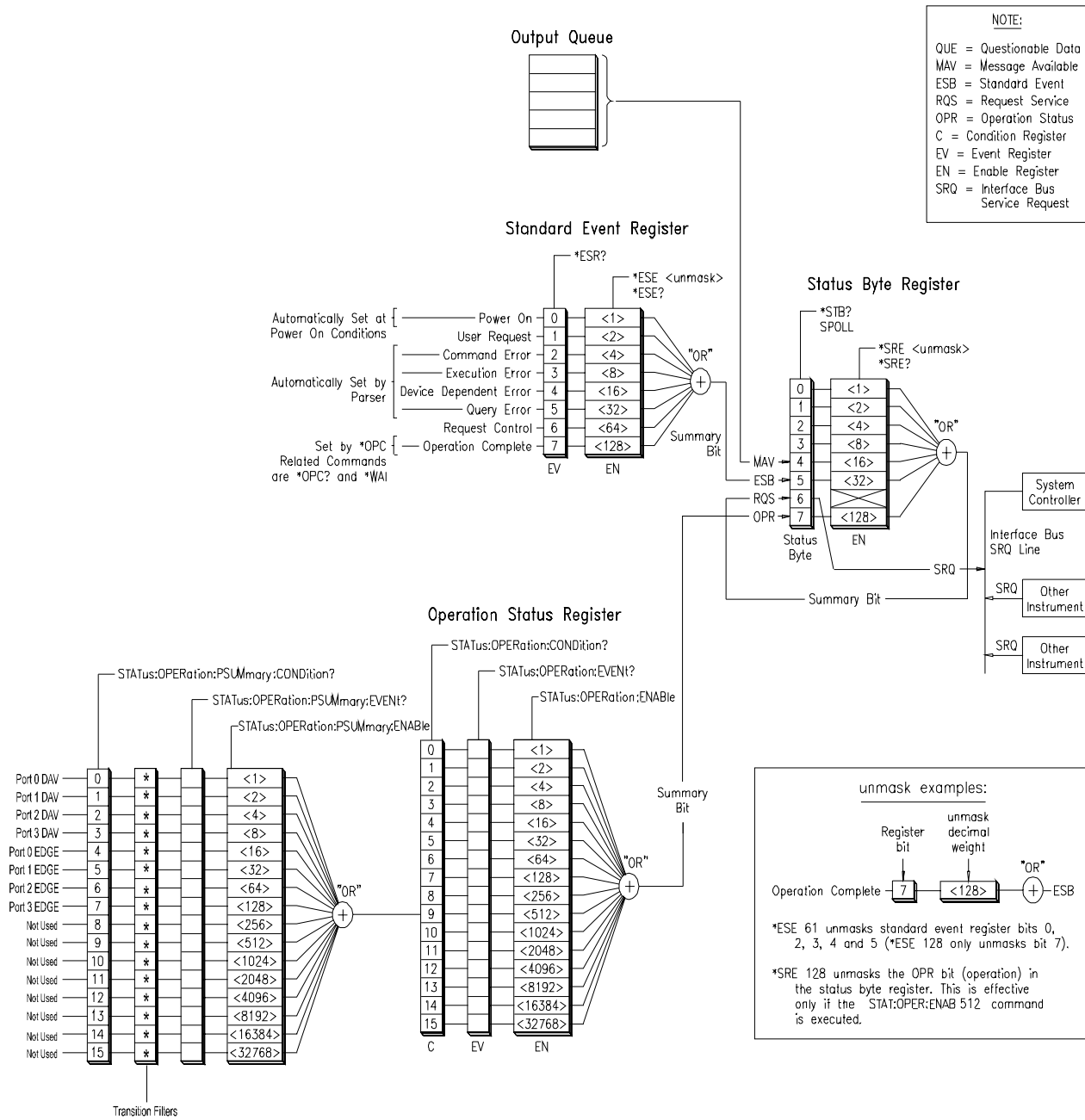

Figure 3-1. Agilent E1459A Status System Register Diagram

STATus:OPERation:CONDition?

Returns the value of the Operation Status Condition Register as a signed 16 bit integer.

Parameters None

- Comments**
- The only bit in this register used by the Agilent E1459A is bit 9 (decimal weight 512) which contains the summary of the Operation Status Port register.
 - The Status Operation Condition register is **not** cleared by this command. It is cleared only by executing the PSUMmary:EVENT command.
 - *RST clears all Status Operation Conditions.
 - *CLS does not affect the contents of the of the Status Operation Conditions.
 - The STATus:PRESet command does not affect the Status Operation Conditions.

STATus:OPERation:ENABLE <mask>

Sets the value of the OPERation Status Enable Register.

Parameters

Parameter Name	Parameter Type	Range of Values	Default
<mask>	numeric	-32768 to 32767 (0000 _h to FFFF _h)	0

- Comments**
- <mask> determines which OPERation Status conditions are summed. See Figure 3-1. The events detected in the Port Summary Status Register are reported in bit 9 of the Operation Status Register which in turn is reported in bit 7 of the Status Byte Register.
 - *RST and *CLS do not affect the value of the enable mask.
 - STATus:PRESet sets the value of the enable mask to 0.

Example STAT:OPER:ENAB 0xFFFF

Enable all bits of the Operation Status Enable Register

STATus:OPERation:ENABLE?

Returns the value of the OPERation Status Enable Register as a signed 16 bit integer.

Parameters None

Comments

- The only defined bit is bit 9 which is the summary of the Data Available and Edge Status for Ports 0, 1, 2, and 3. See Figure 3-1.

STATus:OPERation[:EVENT]?

Returns the value of the OPERation Status Event Register as a signed 16 bit integer and then clears the register to 0.

Parameters None

Comments

- The only bit in the OPERation Status Register used by the Agilent E1459A is bit 9 (decimal weight 512) which contains the summary of the Operation Status Port Register. This is a destructive read so that all register bits are cleared after the read is executed.
- *RST does not affect the contents of the Status Operation Event Register.
- *CLS clears the contents of the Status Operation Event Register.
- STAT:PRESet does not affect the contents of the Status Operation Event Register but does disable reporting the summary of this register in the Status Byte Register (STB?).

STATus:OPERation:PSUMmary:CONDition?

Returns the value of the OPERation Status Port Summary Condition Register as a signed 16 bit integer.

Parameters None

Comments

- Bits 0 through 3 reflect Data Available on Ports 0 through 3 respectively; bits 4 through 7 reflect edge events on Ports 0 through 3 respectively. See Figure 3-1.
- Note: This command does not clear the Port summary Condition Register. The register is cleared only by removing the the condition itself. For example, MEAS:DIG:DATA0 will clear Bit 0 if it was set.
- *RST clears all Status Operation Port Conditions.
- *CLS does not affect the contents of the Status Operation Port Register Conditions.
- The STAT:PRESet command does not affect the Status Operation Port Register contents.

STATus:OPERation:PSUMmary:ENABLE <mask>

Sets the value of the OPERation Status Port Summary Enable Register.

Parameters

Parameter Name	Parameter Type	Range of Values	Default
<mask>	numeric	-32768 to 32767 (0000 _h to FFFF _h)	0

Comments

- This mask determines which Operation Status Port Summary Events are summed and reported in bit 9 of the Operation Status Register. Bits 0 through 3 reflect Data Available on Ports 0 through 3 respectively; bits 4 through 7 reflect edge events on Ports 0 through 3 respectively. See Figure 3-1.
- *RST and *CLS do not affect the value of the enable mask.
- STATus:PRESet sets the value of the enable mask to 0.

Example STAT:OPER:PSUM:ENAB 0xFFFF

Enables all bits of the Operation Status Port Summary Enable Register

STATus:OPERation:PSUMmary:ENABLE?

Returns the value of the Operation Status Port Summary Enable Register as a signed 16 bit integer.

Parameters None

STATus:OPERation:PSUMmary[:EVENT]?

Returns the value of the Operation Status Port Summary Event Register as a signed 16 bit integer and then clears the register to 0.

Parameters None

- Comments**
- This is a destructive read so that all register bits are cleared after the read is executed.
 - *RST does not affect the contents of the Status Operation Port Summary Event Register.
 - *CLS clears the contents of the Status Operation Event Port Register.
 - STAT:PRESet does not affect the contents of the Status Operation Event Port Summary register but does disable the reporting of the summary of this register in bit 9 of the Status Operation Register.

STATus:PRESet

Presets the Status system registers and conditions.

Parameters None

- Comments**
- Resets the following registers and conditions:

Register	Action	Register	Action
Status Byte	none	OPER Status condition	none
Standard Event event	none	OPER Status event	none
Standard Event enable	presets to 0	OPER Status enable	presets to 0
QUES Status Condition	none	OPER PSUM condition	none
QUES Status Event	none	OPER PSUM event	none
QUES Status enable	presets to 0	OPER PSUM enable	presets to 0
		all transition filters	none

STATus:QUEStionable:CONDition?

Always returns a 0.

Note The Questionable Status Condition, Event, and Enable registers exist for SCPI compliance only. No status bits are defined or reported in these registers.

Parameters None

Comments

- No bits are defined.
- *RST clears all Status Questionable Conditions.
- *CLS does not affect the contents of the Status Questionable Conditions.
- The STAT:PRESet command does not affect the Status Questionable Conditions.

STATus:QUEStionable:ENABLE <mask>

Sets the value of the QUEStionable Status Enable Register.

Note The Questionable Status Condition, Event, and Enable registers exist for SCPI compliance only. No status bits are defined or reported in these registers.

Parameters None

Comments

- No bits are defined.
- *RST and *CLS do not affect the value of the enable mask.
- The STAT:PRESet command sets the value of the enable mask to 0.

STATus:QUEStionable:ENABle?

Returns the value of the QUEStionable Status Enable Register as a signed 16 bit integer.

Note The Questionable Status Condition, Event, and Enable registers exist for SCPI compliance only. No status bits are defined or reported in these registers.

Parameters None

Comments

- No bits are defined.

STATus:QUEStionable[:EVENT]?

Returns the value of the QUEStionable Status Event Register as a signed 16 bit integer and then clears the register to 0.

Note The Questionable Status Condition, Event, and Enable registers exist for SCPI compliance only. No status bits are defined or reported in these registers.

Parameters None

Comments

- No bits are defined.
- This is a destructive read so that all register bits are cleared after the read is executed.
- *RST does not affect the contents of the Status Questionable Event Register.
- *CLS clears the contents of the Status Questionable Event Register.
- STAT:PRESet does not affect the contents of the Status Questionable Event Register but does disable reporting the summary of this register in the Status Byte register (STB?)

SYSTem:ERRor?

Queries the error register for the error value and string to identify the error. The errors are held in an error buffer and read on a First-In-First-Out basis.

Parameters None

- Comments**
- Returns the error number and string. If no errors are in the error buffer, the command returns:
+0, "No error"
 - *CLS clears the error buffer.
 - *RST does not affect the error buffer
 - Refer to Appendix C for possible error messages.

Example SYST:ERR?

Requests the error messages.

SYSTem:VERSion?

Returns the SCPI version to which this module complies.

Parameters None

- Comments**
- Returns a decimal value in the form:YYY.R where YYY is the year and R is the revision number within that year. Since there is no SCPI subsystem defined for Digital I/O or Event Interrupts, the version returned will be:
1990.0

IEEE 488.2 Common Commands

The following table lists the IEEE 488.2 Common Commands listed by functional group that can be executed by the Agilent E1459A Digital Input / Interrupt Module. However, commands are listed alphabetically in the reference. Example are shown in the reference when the command has parameters or returns a non-trivial response; otherwise, the command string is as shown in the table. For additional information, refer to IEEE Standard 488.2-1987.

Command	Title	Description
*CLS	Clear Status Registers	Clears all STATus event registers and clears the error queue.
*ESE <mask>	Event Status Enable	Sets the bits in the Event Status Enable Register. <mask> has a range of 0 through 255 and must be entered in decimal format.
*ESE?	Event Status Enable Query	Returns the current programmed value of the Event Status Enable Register.
*ESR?	Event Status Register Query.	Queries and clears contents of the Standard Event Status Register.
*IDN?	Identification query	Returns the (unquoted) identification string: HEWLETT-PACKARD,E1459A/Z2404B,0,revision
*OPC	Operation Complete	This command always immediately sets the operation complete bit (bit 0) in the Standard Event Register because there are never any pending operations.
*OPC?	Operation Complete Query	This command always returns a 1 since there are never any pending operations.
*RCL<state>	Recalls stored instrument state from memory	Recalls the specified stored instrument state where <state> has a value of 0 through 9. The following conditions or settings are saved/recalled: debounce time, positive edge detect, positive edge mask, negative edge detect, negative edge mask, QUEStionable and OPERation PSUMmary Status Enable Registers, QUEStionable and OPERation Status Event Register, QUEStionable and OPERation PORT Status Event Register, QUEStionable and OPERation PSUM Status Event Register.
*RST	Resets the module	Resets the module to the settings shown in the "Power-On and Reset State" table following the individual common command descriptions.
*SAV<state>	Save state to memory	Saves the present instrument state in the specified memory location (1 to 9). Refer to *RCL.
*SRE <mask>	Service Request Enable	Sets the bits in the Service Request Enable Register. <mask> has a range of 0 through 255 and must be entered in decimal format.
*SRE?	Service Request Enable Query	Returns the current programmed value of the Service Request Enable Register.
*STB?	Status Byte	Returns the current value of the Status Byte Register.
*TRG	Bus Trigger	*TRG is not supported on the Agilent E1459A.
*TST?	Self-Test	Returns "0" if self-test passed. Returns "1" if read of ID register (00 _h) failed, returns "2" if read of Device Type Register (02 _h) failed, "20 _n " if interrupt test on Port <i>n</i> failed. Instrument state returned to the power-on / reset state after *TST?
*WAI	Wait to Complete	Prevents execution of commands until the No Operation Pending message is true. Since each command is fully executed at the time of execution, the No Operation Pending message is always true and the *WAI command always immediately executes when received.
*EMC <n>	Enable Macro	Enables execution of macro <n>.
*EMC? <n>	Enable macro query	Queries execution state of macro <n>.
*RMC	Remove macros	Deletes all macros.
*LMC?	List macros	Lists macros by name.
*DMC	Define macro	Defines a macro.
*GMC?	Menu query	Gets results of menu query.
*PMC	Purge macros	Purges all system macros.

Command Quick Reference

Command Subsystem	Description	See Also
DIAG:SYSR:STAT? :ENAB <state> :ENAB?	Returns the value of the Watchdog Timer state (1=asserted, 0=not asserted). Turns the Watchdog Timer ON or OFF. Returns the enabled state of the Watchdog Timer as either a +1, or +0.	page 41 page 41 page 42
DISP:MON:PORT <port> :MON:PORT? [MIN MAX DEF] :MON:PORT:AUTO <state> :MON:PORT:AUTO? :MON[:STAT] <state> :MON[:STAT]?	Sets display monitor port (channel) or automatic mode. Returns the port (channel) number of the current display. Sets the automatic mode for the Display Monitor on or off. Returns the state of the automatic display mode; either +0 or +1. Turns the Display mode on or off. Returns the value of the Display Monitor State; +0 (OFF) or +1 (ON).	page 43 page 44 page 44 page 44 page 45 page 45
INPn:CLOC[:SOUR] EXT INT :CLOC[:SOUR]? :DEB:TIM <time> [MIN MAX DEF] :DEB:TIM? [MIN MAX DEF]	Specifies the input circuitry clock source for Port <i>n</i> . Returns the programmed value of the input clock source for Port <i>n</i> . Programs the channel input debounce time for Port <i>n</i> . Returns the current debounce time as a floating point number.	page 46 page 47 page 47 page 48
MEAS:DIG:DATA <i>n</i> [:type][:VAL]? :DIG:DATA <i>n</i> [:type]:BIT <i>m</i> ?	Returns contents of Current Value Register(s) for the specified Port <i>n</i> . Returns value of BIT <i>m</i> of Channel Data Register for specified Port <i>n</i> .	page 49 page 50
MEM:DEL:MACR <name>	Deletes the MACRO command defined by the name <name>.	page 51
[SENS:]EVEN:PORT <i>n</i> :DAV? :PORT <i>n</i> :DAV:ENAB <state> :PORT <i>n</i> :DAV:ENAB? :PORT <i>n</i> :EDGE? :PORT <i>n</i> :EDGE:ENAB <state> :PORT <i>n</i> :EDGE:ENAB? :PORT <i>n</i> :NEDG? :PORT <i>n</i> :NEDG:ENAB <mask> :PORT <i>n</i> :NEDG:ENAB? :PORT <i>n</i> :PEDG? :PORT <i>n</i> :PEDG:ENAB <mask> :PORT <i>n</i> :PEDG:ENAB? :PSUM:DAV? :PSUM:EDGE?	Returns status of DAVailable Event for Port <i>n</i> as either +0 or +1. Enables Data Available interrupt into Port <i>n</i> by EXT clock source. Returns state of DAVailable Event Enable for Port <i>n</i> as either +0 or +1. Returns status of Edge Detect Event for Port <i>n</i> as either +0 or +1. Enables / disables an edge event interrupt for Port <i>n</i> . Returns value of the Edge Event Enable for Port <i>n</i> as a signed integer. Returns value of Negative Edge Detect Register for 16 bits of Port <i>n</i> . Sets the Negative Edge Detection Mask for Port <i>n</i> . Returns value of Negative Edge Detection Mask as a 16 bit integer. Returns value of Positive Edge Detect Register for 16 bits of Port <i>n</i> . Sets the Positive Edge Detection Mask for Port <i>n</i> . Returns value of the Positive Edge Detection Mask as a 16 bit integer. Returns status of DAVailable Event for ALL ports as a 16 bit integer. Returns the status of the edge events for ALL ports.	page 52 page 53 page 53 page 54 page 54 page 55 page 55 page 56 page 56 page 57 page 57 page 58 page 58 page 59
STAT:OPER:COND? :OPER:ENAB <mask> :OPER:ENAB? :OPER[:EVEN]? :OPER:PSUM:COND? :OPER:PSUM:ENAB <mask> :OPER:PSUM:ENAB? :OPER:PSUM[:EVEN]? :PRES :QUES:COND? :QUES:ENAB <mask> :QUES:ENAB? :QUES[:EVEN]?	Returns value of Operation Status Condition Register as 16 bit int. Sets the value of the OPERation Status Enable Register. Returns value of OPERation Status Enable Register as 16 bit integer. Returns value of OPERation Status Event Register as 16 bit integer. Returns value of OPERation Status Port Condition Register as 16 bit int. Sets the value of the OPERation Status Port Enable Register. Returns value of Operation Status Port Enable Register as 16 bit integer. Returns value of Operation Status Port Event Register as 16 bit integer. Presets the Status system registers and conditions. Returns value of Questionable Status Condition Register as 16 bit int. Sets the value of the QUEStionable Status Enable Register. Returns value of QUEStionable Status Enable Register as 16 bit integer. Returns value of QUEStionable Status Event Register as 16 bit integer.	page 62 page 62 page 63 page 63 page 63 page 64 page 64 page 65 page 65 page 66 page 66 page 67 page 67
SYST:CDES? <number> :CTYP? <number> :ERR? :VERS?	Returns the module description. Returns the module card type. Queries the error register for error value and string to identify the error. Returns the SCPI version to which this module complies.	page 68 page 68 page 69 page 69

Appendix A

Agilent E1459A Specifications

Max Input Voltage: Between High and Low terminal of Each Channel: 60V DC.
 Between Channels or Between any terminal and chassis: 125V AC or DC.

Module Size/Device Type: C, Register-based.

Connectors Used: P1 and P2.

Number of Slots: 1

VXIbus Interface Capability: Interrupter, D16.

Interrupt Level: 1-7, selectable.

Power Requirements: Voltage: +5Vdc
 Peak Module Current IPM (A): 0.19
 Dynamic Module Current IDM (A): 0.10

Watts/Slot: 1.0

Minimum Pulse Width: 100µs + debounce time.

Operating Range:

	Nominal Input Voltages			
	5	12	24	48
Threshold Voltage				
MIN	1	2.5	7	14
MAX	4	9.5	17	31
Input Current Ma at Nominal Voltage	0.5	1.3	2.8	5.8

Debounce: Programmable from 16 µs to 1074 S.

5 Volt Supply: Output voltage : 4.5 to 5.5 V DC. Maximum output current: 16 mA.

Typical Time to Read 16-bit Word: 4 µs using register access.

Terminal Module: Screw type, removable, maximum wire size 16AWG.

Input Circuit:

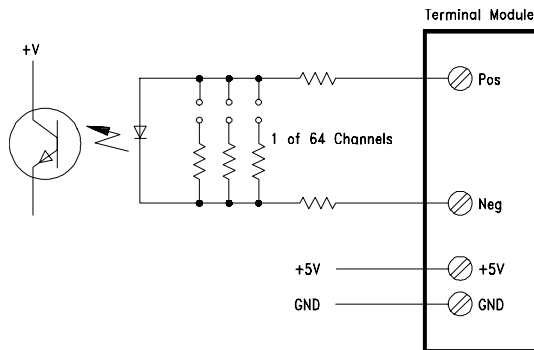

Appendix B

Agilent E1459A Register Definitions

Overview

The Agilent E1459A Isolated Digital Input/Interrupt module is a register-based slave device. There are 64 isolated inputs which can be used for detecting rising and/or falling edges independently. Each 16 channels has a set of registers used to define the detection of interrupt conditions. Listed below are the different register types on this module.

- **ID Register** - Identifies Agilent as the manufacturer, and that the card is an A16 register based device.
- **Device Type Register** - Identifies card as a Agilent E1459A.
- **Status/Control Register** - When read it returns device specific status information. When written it to, it sets control bits. Bit 4 specifies the registers for the upper or lower 32 channels.
- **Edge Interrupt Status Register** - This register indicates which Port has detected an edge interrupt.
- **Data Available Status Register (DAV)** - This register indicates which register has been externally triggered and has data available.
- **Watchdog Timer Control/Status Register** - The watchdog timer on the module is enabled and pet using this register.
- **Command Register** - There are two of these registers, each controls two ports; used to control triggering and enabling interrupts.
- **Channel Data Register** - There are four of these registers, one for each port; these registers contain the current channel data.
- **Positive Edge Detect Register** - There are four of these registers, one for each port; used to capture transitions from low to high levels.
- **Negative Edge Detect Register** - There are four of these registers, one for each port; used to capture transitions from high to low levels.
- **Positive Mask Register** - There are four of these registers, one for each port; these registers enable data to be captured in the Positive Edge Detect Registers.
- **Negative Mask Register** - There are four of these registers, one for each port; these registers enable data to be captured in the Negative Edge Detect Registers.
- **Debounce Clock Register** - There are two of these registers, one for the lower two ports and one for the upper two ports. These registers control the clock speed of the debouncers.

Addressing the Registers

To read or write to specific registers you must address a particular register within a module. The registers within a module are located using a fixed offset. The module address is based upon the module's logical address. There are two basic ways of accessing registers. One method uses the logical address directly to access a particular card using VXI:READ and VXI:WRITE commands through a command module. The other method can be used with an embedded controller that locates A16 data space within its memory map. The memory mapping allows registers to be directly read or written with moves to/from memory.

The factory setting of the logical address dip switch is 144 (90 hex). This value is used in the following examples.

Register Access with Logical Address

When using the Agilent E1406 Command Module to access registers via VXI:READ and VXI:WRITE commands, the logical address is used to determine which VXI module is being accessed.

Note Refer to the Agilent E1406 Command Module documentation for usage of the VXI:READ and VXI:WRITE commands and other related commands.

The following commands are sent to the Agilent E1406 Command Module via the GPIB. The following example shows a portion of an BASIC program. The controller could either be external or embedded in the VXI Mainframe. This example shows the Status/Control Register being accessed.

```
! Writes FFFF hex to Control Register  
OUTPUT 70900;"VXI:WRITE 144,4,#HFFFF"
```

```
! Reads from Status Register  
OUTPUT 70900;"VXI:READ? 144,4"  
ENTER 70900;Status
```

Register Access with Memory Mapping

When using an embedded controller VXI A16 address space is usually mapped to some block of memory within the controllers addressable memory space.

Note Refer to your embedded controller manual to determine where VXI A16 is mapped. There may be other methods of accessing the VXI backplane. What is shown here is the method in which A16 addresses are calculated for a module.

For example, for the Agilent 75000 Series C Mainframe with an Agilent E1406 Command Module, VXI A16 address space starts at 1F0000_h (_h = HEX). In the Agilent E1406 Command Module, the A16 space is divided so modules are addressed only at locations beginning with C000_h within A16. Each module is allocated 64 register addresses (40_h). The module base address is related to the logical address set by the logical address switch on the module:

$$\text{base address (}_h\text{)} = (\text{logical address}_h) * 40_h + \text{C000}_h$$

For the Agilent E1459A, the factory-set logical address is 144 (90_h), so to address the Status/Control register of an Agilent E1459A using the Agilent E1406 Command Module:

$$\text{base address} = (90_h) * (40_h) + \text{C000}_h = \text{E400}_h$$

$$\text{register address} = [\text{A16 location}]_h + [\text{base addr}]_h + [\text{register offset}]_h$$

$$\text{register address} = 1\text{F0000}_h + \text{E400}_h + 04_h = 1\text{FE404}_h$$

Register Definitions

The following registers can be accessed on the Agilent E1459A:

- ID Register (base + 00_h)
- Device Type Register (base + 02_h)
- Status/Control Register (base + 04_h)
- Edge Interrupt Status Register (base + 06_h)
- Data Available Status Register (base + 08_h)
- Watchdog Timer Control/Status Register (base + 0A_h)
- Command Register of Port 0/2 (base + 10_h)
- Channel Data Register of Port 0/2 (base + 12_h)
- Positive Edge Detect Register of Port 0/2 (base + 14_h)
- Negative Edge Detect Register of Port 0/2 (base + 16_h)
- Positive Mask Register of Port 0/2 (base + 18_h)
- Negative Mask Register of Port 0/2 (base + 1A_h)
- Debounce Clock Control/Status Register of Port 0 and 1/Port 2 and 3 (base + 1E_h)
- Command Register of Port 1/3 (base + 20_h)
- Channel Data Register of Port 1/3 (base + 22_h)
- Positive Edge Detect Register of Port 1/3 (base + 24_h)
- Negative Edge Detect Register of Port 1/3 (base + 26_h)
- Positive Mask Register of Port 1/3 (base + 28_h)
- Negative Mask Register of Port 1/3 (base + 2A_h)
- Debounce Clock Control/Status Register of Port 0 and 1/Port 2 and 3 (base + 2E_h)

Manufacturer ID Register

ID register (base = 00_h) is a read only register. For the Isolated Digital Input/Interrupt, a read of the ID register returns FFFF_h since the multiplexers are manufactured by Agilent Technologies and are A16 only, register-based devices.

Manufacturer ID Register (base + 00_h)

b + 0 _h	15	14	13	12	11	10	9	8	7	6	5	4	3	2	1	0
Write	No Effect															
Read	Manufacturer ID															

* Returns FFFF_h = Agilent Technologies A16 (only) register-based device

Device Type Register

Device Type register (base = 02_h) is a read only register. For the Isolated Digital Input/Interrupt, a read of the Device Type register returns 0154_h. This indicates it is a model Agilent E1459A.

Device Type Register (base + 02_h)

b + 2 _h	15	14	13	12	11	10	9	8	7	6	5	4	3	2	1	0
Write	No Effect															
Read	Always Returns 0154 _h															

Status/Control Register

Status/Control register (base = 04_h) can be read and written. Many of the bits perform control functions. Reading this register returns the current state of the status bits for the module.

Status/Control Register (base + 04_h)

b + 4 _h	15	14	13	12	11	10	9	8	7	6	5	4	3	2	1	0
Write	Undefined										D	I	BS	Undefined		R
Read	Undefined	M	Undefined			D IRQ		E IRQ		Undefined	D	I	BS	Undefined		R

NOTE: Bits 8 and 9 are returned in the IACK response in the same bit positions.

WRITE

R = Reset to power-on state by writing a "1" in this bit (Must be set back to "0").

BS = Bank Select. When "0" Port 0 and Port 1 data are accessed in registers b + 10_h through b + 2E_h. When "1" Port 2 and Port 3 data are accessed in the same registers.

I = Interrupt Enable. When set to 1, an IRQ can be generated with an edge event (assuming one is enabled).

D = Data Ready Enable. When set to 1 an IRQ can be generated with a DAVX line is asserted.

READ

E IRQ = When "1" it indicates that an INTRX line has transitioned from being asserted.

D IRQ = When "1" it indicates that a DAVX line had been asserted.

M = MODID bit = "0" module has been selected.

Bit 0 is the reset bit. Writing a "1" will force the card into reset. It must be written back to "0" for normal operation of the card. The state of this bit is returned on a read of this register.

Bit 4 is used to control which set of port registers are being accessed. Due to the number of registers on this card, it is necessary to switch between registers. This bit when set to "0" allows access to Port 0 and Port 1 data in registers 10_h through 2E_h. This corresponds to the first 32 channels. When this bit is a "1". Port 2 and Port 3 can be accessed in these same register locations. The state of this bit is returned on a read of this register.

Bit 5 controls if edge interrupts are enabled ("1") or not ("0"). If enabled an edge interrupt will generate an IRQ if other registers are properly enabled. At least one port must have the Edge Enable bit set in the command register, and have at least one bit enabled in one of the mask registers. If an edge event occurs, IRQ will be asserted. This can be verified by reading the Edge Interrupt Status Register to assure none are asserted. If any are asserted the Edge Detect Register holding the edge event must be cleared. The state of this bit is returned on a read of this register.

Bit 6 controls if IRQ will be asserted when data becomes available due to an external trigger on any of the ports. A "1" enables the IRQ and a "0" disables it. The interrupt will only occur if the following is true: The command register for at least one of the ports must have the data ready enable bit set in order to generate an interrupt. This can be verified by reading the Data Available Status Register to assure that none are asserted. If any are asserted, the data available indication will be cleared by reading any of the registers associated with the port. The state of this bit is returned on a read of this register.

Bit 8 is a read only bit. When bit 5 is enabled, edge interrupts are enabled. It indicates if an edge interrupt has occurred on any of the ports since the last time IRQ was asserted. During the IACK cycle this bit will also appear as bit 8 of the IACK response. It will then be reset. If bit 5 is not enabled this bit can be polled to detect an edge event on any register. All pending edge events must be cleared (read) before this bit can be reasserted.

Bit 9 is a read only bit. When bit 6 is enabled, data available interrupts are enabled. It indicates if an external trigger has occurred on any of the ports since the last time IRQ was asserted. During the IACK cycle this bit will also appear as bit 9 of the IACK response. It will then be reset. If bit 6 is not enabled this bit can be polled to detect an external trigger on any port. All pending data available must be cleared (read) before this bit is reasserted.

Note In applications requiring interrupts, a commander will have to be assigned as the interrupt handler of this module

Bit 14 is the MODID bit. When a "0" is returned in bit 14 then the module has been selected with a high state on the P2 MODID line. If a "1" is returned then the module has not been selected. This bit is read only.

Edge Interrupt Status Register

The Edge Interrupt Status Register (base + 06_h) indicates if an edge interrupt has been detected for any of the 4 ports. There are 4 bits used in this register, one for each port. A bit will remain asserted ("1") in this register until all edge events for a port have been cleared. Bit 0 is used for Port 0, bit 1 for Port 1, bit 2 for Port 2, and bit 3 for Port 3. These bits reflect the state of the INTR lines available on the terminal module. The INTR lines will be asserted when a bit is "1" in this register. This register has no effect if it is written.

Edge Interrupt Status Register (base + 06h)

b + 6 _h	15	14	13	12	11	10	9	8	7	6	5	4	3	2	1	0
Write	No Effect															
Read	Always Returns FFF _h												INTR3	INTR2	INTR1	INTR0

INTRX = Edge interrupt for port 0 - 3. A "1" means an edge event has been detected within the corresponding port and a "0" means one hasn't. A bit set to "1" will only return to "0" by reading the interrupt register that caused the edge detection to occur.

Data Available Status Register

The Data Available Status Register (base + 08_h) indicates if an external trigger has occurred for any of the 4 ports. There are 4 bits used in this register, one for each port. A bit will be asserted when the DAV ENAB bit and the INT/EXT bit are set ("1") in the command register for a port, and an external trigger occurs. (An external trigger occurs on a negative edge). Bit 0 is used for Port 0, bit 1 for Port 1, bit 2 for Port 2, and bit 3 for Port 3. These bits reflect the state of the DAV lines available on the terminal module. The DAV lines will be asserted when a bit is "1" in this register. This register has no effect if it is written.

Data Available Register (base + 08h)

b + 8 _h	15	14	13	12	11	10	9	8	7	6	5	4	3	2	1	0
Write	No Effect															
Read	Always Returns FFF _h												DAV3	DAV2	DAV1	DAV0

DAVX = Data available in Port 0 - 3. A "1" means that new data has been latched into the channel data register for that port. A "0" means it has not been triggered yet. A bit set to "1" will only return to "0" by reading the DAV register associated with that port.

Watchdog Timer Control/Status Register

The Watchdog Timer Control/Status Register (base + 0A_h) can be read or written. A read of this register will automatically "pet" the Watchdog Timer and will return a "1" in bit zero when the Watchdog Timer is enabled. A "0" means the timer is disabled. Bit 2 returns the current state of the timer. If it is at "1" the timer is asserted and, if enabled, would assert SYSRESET. The timer must be "pet" periodically to keep it from asserting its output. Once the timer is unasserted and pet it will remain unasserted, as long as it is pet within its pet time. The timer is pet automatically whenever this register is read. Once the timer is unasserted, it can then be enabled. It will then assert SYSRESET if it is not pet continuously at least once within its pet time.

Watchdog Timer Control/Status Register (base + 0Ah)

b + A _h	15	14	13	12	11	10	9	8	7	6	5	4	3	2	1	0
Write	No Effect															DOGENAB
Read	Always Returns FFF _h												1	1	DOGSTATE	DOGENAB

DOGENAB = "0" the watchdog timer is disabled. "1" = enabled.

DOGSTATE = "0" the watchdog timer is not asserted. "1" the watchdog timer is asserted. (If enabled when it is a "1" it will assert SYSRESET). The watchdog timer can be "pet" by doing a read of this register. The "pet" time is selected by 2 jumpers on the PC board.

Command Register Port 0/2

The Command Register for Port 0/2 (base + 10_h) can be read or written. It contains three bits used to control operating characteristics of the port. If bit 4 of the Control/Status Register is low ("0"), Port 0 is accessed. If bit 4 is high ("1"), Port 2 will be accessed. All control bits default to "0" as the reset state.

Bit 0 enables ("1") and disables ("0") an edge event to be reported in the Edge Interrupt Status Register. If this bit is "1" then any edge event captured in either the positive or negative edge detect registers will appear in the Edge Interrupt Status Register. An interrupt will only occur on the backplane (IRQ) if bit 5 in the Status Register is set. If bit 0 is set to "0" then an edge event will not be detected in the Edge Interrupt Status Register and can not cause an interrupt. When this bit is enabled the INTR line on the terminal module is active, and will be asserted as long as an edge event is captured in either edge detection register. The state of this bit is returned on a read of the register.

Bit 1 is used to select between internal and external triggering. When set to "0", the internal clock is used to latch in data. When in external trigger, the EXT input (available on the terminal module) is used to clock data into the data capture circuitry on the falling edge. The state of this bit is returned on a read of this register.

Bit 2 enables ("1") and disables ("0") an external trigger being reported in the Data Available Status Register. If this bit and bit 1 are set to "1", an external trigger will cause data to be latched into the data capture circuitry. This will cause the DAV line to be asserted and "1" to appear in the Data Available Status Register. Once read, the DAV line will be unasserted, and

the bit in the Data Available Status Register will also be unasserted. An interrupt will only occur on the backplane (IRQ) if bit 6 in the Status Register is set. The state of this bit is returned on a read of this register.

Command Register Port 0/2 (base + 10h)

b + 10 _h	15	14	13	12	11	10	9	8	7	6	5	4	3	2	1	0
Write	No Effect												DAV ENAB	INT/EXT	EDGE ENAB	
Read	Always Returns FFF _h												1	DAV ENAB	INT/EXT	EDGE ENAB

For reading and writing, when BS = 0 in the Status/Control Register, the data for Port 0 is accessed. When BS = 1, the data for Port 2 is accessed.

EDGE ENAB = "1" allows an edge interrupt (INTR for Port 0/2 to cause an interrupt, if enabled in the Status/Control register. When "0" edge interrupts from Port 0/2 are disabled.

INT/EXT = "0" data will be latched using the internal clock. "1" data is latched using EXT0/2 input.

DAV ENAB = "1" allows the DAV0/2 line to cause an interrupt if enabled in the Status/Control Register. The DAV line is asserted when data is latched. This should only be enabled when in external trigger mode. When set to "0" the DAV0/2 line cannot cause an interrupt.

Caution A potential hazard exists if software were to improperly program the Agilent E1459A to post data-capture IRQ's with the internally selected 1.0 MHz clock source. In this situation, a DAV interrupt would be posted each microsecond (if software were able to service at that rate), and would cause software to continuously vector to interrupt service upon each "return from service." Therefore, the Agilent E1459A should never be programmed to generate DAV interrupts with the internal clock source selected. (If bit 1 of the Command Register Word is set to a one, then bit 2 must always be set to zero.)

In the Agilent E1459A the Data Ready Marker is guaranteed to be cleared when the clock source is switched from internal to external. Therefore, any capture clock which occurs within the internal/external clock selection interval will not post a marker to the control FPGA and will be lost.

Channel Data Register Port 0/2

The Channel Data Register for Port 0/2 (base + 12_h) is read only. This register returns the current (last) data that has been clocked into the edge detection circuitry based on either the internal or external trigger source. If bit 4 of the Control/Status Register is low ("0"), Port 0 is accessed. If bit 4 is high ("1"), Port 2 data will be accessed.

Channel Data Register Port 0/2 (Channels 0-15/32-47) (base + 12h)

b + 12 _h	15	14	13	12	11	10	9	8	7	6	5	4	3	2	1	0
Write	No Effect															
Read	Ch15	Ch14	Ch13	Ch12	Ch11	Ch10	Ch9	Ch8	Ch7	Ch6	Ch5	Ch4	Ch3	Ch2	Ch1	Ch0
Read	Ch47	Ch46	Ch45	Ch44	Ch43	Ch42	Ch41	Ch40	Ch39	Ch38	Ch37	Ch36	Ch35	Ch34	Ch33	Ch32

Channels 0 through 15 are accessed when BS = 0 in the Status/Control Register.

Channels 32 through 47 are accessed when BS = 1 in the Status/Control Register.

Positive Edge Detect Register Port 0/2

The Positive Edge Detect Register for Port 0/2 (base + 14_h) is read only. This register captures any low to high transitions with a "1" in this register for any channel that has been enabled. A channel is enabled by setting a corresponding bit in the Positive Mask Register. Once the register is read, the data is automatically cleared. A transition is only seen if it is held long enough to pass through the debouncers. If bit 4 of the Control/Status Register is low ("0"), Port 0 data is accessed. If bit 4 is high ("1"), Port 2 data will be accessed.

Positive Edge Detect Register Port 0/2 (Channels 0-15/32-47) (base + 14h)

b + 14 _h	15	14	13	12	11	10	9	8	7	6	5	4	3	2	1	0
Write	No Effect															
Read	Ch15	Ch14	Ch13	Ch12	Ch11	Ch10	Ch9	Ch8	Ch7	Ch6	Ch5	Ch4	Ch3	Ch2	Ch1	Ch0
Read	Ch47	Ch46	Ch45	Ch44	Ch43	Ch42	Ch41	Ch40	Ch39	Ch38	Ch37	Ch36	Ch35	Ch34	Ch33	Ch32

For Positive/Negative Edge Detect and Mask Registers, channels 0 through 15 are accessed when BS = 0 in the Status/Control Register.

For Positive/Negative Edge Detect and Mask Registers, channels 32 through 47 are accessed when BS = 1 in the Status/Control Register.

Negative Edge Detect Register Port 0/2

The Negative Edge Detect Register for Port 0/2 (base + 16_h) is read only. This register captures any high to low transitions with a "1" in this register for any channel that has been enabled. A channel is enabled by setting a corresponding bit in the Negative Mask Register. Once the register is read, the data is automatically cleared. A transition is only seen if it is held long enough to pass through the debouncers. If bit 4 of the Control/Status Register is low ("0"), Port 0 data is accessed. If bit 4 is high ("1"), Port 2 data will be accessed.

Negative Edge Detect Register Port 0/2 (Channels 0-15/32-47) (base + 16h)

b + 16 _h	15	14	13	12	11	10	9	8	7	6	5	4	3	2	1	0
Write	No Effect															
Read	Ch15	Ch14	Ch13	Ch12	Ch11	Ch10	Ch9	Ch8	Ch7	Ch6	Ch5	Ch4	Ch3	Ch2	Ch1	Ch0
Read	Ch47	Ch46	Ch45	Ch44	Ch43	Ch42	Ch41	Ch40	Ch39	Ch38	Ch37	Ch36	Ch35	Ch34	Ch33	Ch32

Positive Mask Register Port 0/2

The Positive Mask Register for Port 0/2 (base + 18_h) can be read or written. This register enables the Positive Edge Detect Register to capture low to high transitions on individual channels. When a bit is set to "1" in this register it enables that channel to be captured in the corresponding bit in the Positive Edge Detect Register. When a bit is set to "0" it is disabled. If bit 4 of the Control/Status Register is low ("0"), Port 0 data is accessed. If bit 4 is high ("1"), Port 2 data will be accessed.

Positive Mask Register Port 0/2 (Channels 0-15/32-47) (base + 18h)

b + 18 _h	15	14	13	12	11	10	9	8	7	6	5	4	3	2	1	0
Read/Write	Ch15	Ch14	Ch13	Ch12	Ch11	Ch10	Ch9	Ch8	Ch7	Ch6	Ch5	Ch4	Ch3	Ch2	Ch1	Ch0
Read/Write	Ch47	Ch46	Ch45	Ch44	Ch43	Ch42	Ch41	Ch40	Ch39	Ch38	Ch37	Ch36	Ch35	Ch34	Ch33	Ch32

Negative Mask Register Port 0/2

The Negative Mask Register for Port 0/2 (base + 1A_h) can be read or written. This register enables the Negative Edge Detect Register to capture high to low transitions on individual channels. When a bit is set to "1" in this register it enables that channel to be captured in the corresponding bit in the Negative Edge Detect Register. When a bit is set to "0" it is disabled. If bit 4 of the Control/Status Register is low ("0"), Port 0 data is accessed. If bit 4 is high ("1"), Port 2 data will be accessed.

Negative Mask Register Port 0/2 (Channels 0-15/32-47) (base + 1Ah)

b + 1A _h	15	14	13	12	11	10	9	8	7	6	5	4	3	2	1	0
Read/Write	Ch15	Ch14	Ch13	Ch12	Ch11	Ch10	Ch9	Ch8	Ch7	Ch6	Ch5	Ch4	Ch3	Ch2	Ch1	Ch0
Read/Write	Ch47	Ch46	Ch45	Ch44	Ch43	Ch42	Ch41	Ch40	Ch39	Ch38	Ch37	Ch36	Ch35	Ch34	Ch33	Ch32

Debounce Clock Register Port 0 and Port 1/ Port 2 and Port 3

The Debounce Clock Register (base + 1E_h) can be read or written. This register controls the clock rate to the debouncers. There are only two programmable counters for all four ports. Port 0 and Port 1 share one counter. This counter is controlled when bit 4 of the Control/Status Register is "0". Port 2 and Port 3 share the other counter and are accessed when bit 4 of the Control/Status Register is "1". A 2^N counter is used to generate the clock, so times are binary powers. Table 3-1 shows the allowed values for this register. This register is mirrored at address base + 2E_h. Accessing register base + 1E_h is equivalent to base + 2E_h. Programming the register to 0 is equivalent to programming it to 2, and programming it to 3 is the same as 1.

Debounce Clock Register Port 0 and Port 1/Port 2 and Port 3 (base + 1E_h)

b + 1E _h	15	14	13	12	11	10	9	8	7	6	5	4	3	2	1	0
Write	No Effect												DEBOUNCE TIME			
Read	Always Returns FFF _h										0	0	0	DEBOUNCE TIME		

When BS = 0 in the Status/Control Register, the debounce clock for Port 0 and Port 1 are accessed. Port 0 and Port 1 use the same debounce clock. With BS = 0 any value programmed into or read from this register will be the same as the register at b + 2E_h.

When BS = 1 in the Status/Control Register, the debounce clock for Port 2 and Port 3 are accessed. Port 2 and Port 3 use the same debounce clock. With BS = 1 any value programmed into or read from this register will be the same as the register at b + 2E_h.

The following table lists the actual values for the debounce times:

Register Value	Bit pattern (hex)	Clock Frequency	Clock Period	Debounce Time (4 - 4.5 clock periods)
2 (or 0, default)	0002 _h	250 kHz	4 μS	16 - 18 μS
3 (or 1)	0003 _h	125 kHz	8 μS	32 - 36 μS
4	0004 _h	62.5 kHz	16 μS	64 - 72 μS
5	0005 _h	31.25 kHz	32 μS	128 - 144 μS
6	0006 _h	15.63 kHz	64 μS	256 - 288 μS
7	0007 _h	7.81 kHz	128 μS	512 - 576 μS
8	0008 _h	3.90 kHz	256 μS	1.0 - 1.13 mS
9	0009 _h	1.95 kHz	512 μS	2.0 - 2.26 mS
10	000A _h	976 Hz	1 mS	4.1 - 4.6 mS
11	000B _h	488 Hz	2 mS	8.2 - 9.2 mS
12	000C _h	244 Hz	4.1 mS	16.4 - 18.4 mS
13	000D _h	122 Hz	8.2 mS	32.8 - 36.9 mS
14	000E _h	61 Hz	16.4 mS	65.5 - 73.8 mS

Register Value	Bit pattern (hex)	Clock Frequency	Clock Period	Debounce Time (4 - 4.5 clock periods)
15	000F _h	30.5 Hz	32.8 mS	131 - 148 mS
16	0010 _h	15.3 Hz	65.5 mS	262 - 294 mS
17	0011 _h	7.63 Hz	131 mS	524 - 59 mS
18	0012 _h	3.82 Hz	262 mS	1.05 - 1.16 S
19	0013 _h	1.91 Hz	524 mS	2.1 - 2.36 S
20	0014 _h	0.954 Hz	1.05 S	4.2 - 4.72 S
21	0015 _h	0.477 Hz	2.1 S	8.39 - 9.43 S
22	0016 _h	0.238 Hz	4.2 S	16.8 - 18.9 S
23	0017 _h	0.119 Hz	8.39 S	33.6 - 37.8 S
24	0018 _h	60.0 mHz	16.8 S	67.1 - 75 S
25	0019 _h	30.0 mHz	33.6 S	134 - 150 S
26	001A _h	15.0 mHz	67.1 S	268 - 300 S
27	001B _h	7.5 mHz	134 S	537 - 600 S
28	001C _h	3.7 mHz	268 S	1074 - 1200 S
29	001D _h	1.9 mHz	537 S	2147 - 2400 S
30	001E _h	931 mHz	1074 S	4295 - 4800 S
31	001F _h	465.5 μHz	2148 S	8590 - 9600 S

Command Register Port 1/3

The Command Register for Port 1/3 (base + 20_h) can be read or written. It contains three bits used to control operating characteristics of the port. If bit 4 of the Control/Status Register is low ("0"), Port 1 data is accessed. If bit 4 is high ("1"), Port 3 data will be accessed. The operation of these Command Registers is identical to those of Port 0/2.

Command Register Port 1/3 (base + 20h)

b + 20 _h	15	14	13	12	11	10	9	8	7	6	5	4	3	2	1	0
Write	No Effect												DAV ENAB	INT/EXT	EDGE ENAB	
Read	Always Returns FFF _h												1	DAV ENAB	INT/EXT	EDGE ENAB

For reading and writing, when BS = 0 in the Status/Control Register, the data for Port 1 is accessed. When BS = 1, the data for Port 3 is accessed.

EDGE ENAB = "1" allows an edge interrupt (INTR for Port 1/3 to cause an interrupt, if enabled in the Status/Control Register. When "0" edge interrupts from Port 1/3 are disabled.

INT/EXT = "0" data will be latched using the internal clock. "1" data is latched using EXT1/3 input.

DAV ENAB = "1" allows the DAV1/3 line to cause an interrupt if enabled

in the Status register. The DAV line is asserted when data is latched. This should only be enabled when in external trigger mode. When set to "0" the DAV1/3 line cannot cause an interrupt.

Caution A potential hazard exists if software were to improperly program the Agilent E1459A to post data-capture IRQ's with the internally selected 1.0 MHz clock source. In this situation, a DAV interrupt would be posted each microsecond (if software were able to service at that rate), and would cause software to continuously vector to interrupt service upon each "return from service." Therefore, the Agilent E1459A should never be programmed to generate DAV interrupts with the internal clock source selected. (If bit 1 of the Command Register Word is set to a one, then bit 2 must always be set to zero.)

In the Agilent E1459A the Data Ready Marker is guaranteed to be cleared when the clock source is switched from internal to external. Therefore, any capture clock which occurs within the internal/external clock selection interval will not post a marker to the control FPGA and will be lost.

Channel Data Register Port 1/3

The Channel Data Register for Port 1/3 (base + 22_h) is read only. This register returns the current (last) data that has been clocked into the data capture circuitry. If bit 4 of the Control/Status Register is low ("0"), Port 1 data is accessed. If bit 4 is high ("1"), Port 3 data will be accessed. The operation of these Channel Data Registers for Port 1/3 is identical to those of Port 0/2.

Channel Data Register Port 1/3 (Channels 16-31/48-63) (base + 22h)

b + 22 _h	15	14	13	12	11	10	9	8	7	6	5	4	3	2	1	0
Write	No Effect															
Read	Ch31	Ch30	Ch29	Ch28	Ch27	Ch26	Ch25	Ch24	Ch23	Ch22	Ch21	Ch20	Ch19	Ch18	Ch17	Ch16
Read	Ch63	Ch62	Ch61	Ch60	Ch59	Ch58	Ch57	Ch56	Ch55	Ch54	Ch53	Ch52	Ch51	Ch50	Ch49	Ch48

Channels 16 through 31 are accessed when BS = 0 in the Status/Control Register. Channels 48 through 63 are accessed when BS = 1 in the Status/Control Register.

Positive Edge Detect Register Port 1/3

The Positive Edge Detect Register for Port 1/3 (base + 24_h) is read only. If bit 4 of the Control/Status Register is low ("0"), Port 1 data is accessed. If bit 4 is high ("1"), Port 3 data will be accessed. The operation of the Positive Edge Detect Register for Port 1/3 is identical to those of Port 0/2.

Positive Edge Detect Register Port 1/3 (Channels 16-31/48-63) (base + 24h)

b + 24 _h	15	14	13	12	11	10	9	8	7	6	5	4	3	2	1	0
Write	No Effect															
Read	Ch31	Ch30	Ch29	Ch28	Ch27	Ch26	Ch25	Ch24	Ch23	Ch22	Ch21	Ch20	Ch19	Ch18	Ch17	Ch16
Read	Ch63	Ch62	Ch61	Ch60	Ch59	Ch58	Ch57	Ch56	Ch55	Ch54	Ch53	Ch52	Ch51	Ch50	Ch49	Ch48

For Positive/Negative Edge Detect and Mask Registers, channels 16 through 31 are accessed when BS = 0 in the Status/Control Register.

For Positive/Negative Edge Detect and Mask Registers, channels 48 through 63 are accessed when BS = 1 in the Status/Control Register.

Negative Edge Detect Register Port 1/3

The Negative Edge Detect Register for Port 1/3 (base + 26_h) is read only. If bit 4 of the Control/Status Register is low ("0"), Port 1 data is accessed. If bit 4 is high ("1"), Port 3 data will be accessed. The operation of the Negative Edge Detect Register for Port 1/3 is identical to those of Port 0/2.

Negative Edge Detect Register Port 1/3 (Channels 16-31/48-63) (base + 26h)

b + 26 _h	15	14	13	12	11	10	9	8	7	6	5	4	3	2	1	0
Write	No Effect															
Read	Ch31	Ch30	Ch29	Ch28	Ch27	Ch26	Ch25	Ch24	Ch23	Ch22	Ch21	Ch20	Ch19	Ch18	Ch17	Ch16
Read	Ch63	Ch62	Ch61	Ch60	Ch59	Ch58	Ch57	Ch56	Ch55	Ch54	Ch53	Ch52	Ch51	Ch50	Ch49	Ch48

Positive Mask Register Port 1/3

The Positive Mask Register for Port 1/3 (base + 28_h) can be read or written. If bit 4 of the Control/Status Register is low ("0"), Port 1 data is accessed. If bit 4 is high ("1"), Port 3 data will be accessed. The operation of the Positive Mask Register for Port 1/3 is identical to those of Port 0/2.

Positive Mask Register Port 1/3 (Channels 16-31/48-63) (base + 28h)

b + 28 _h	15	14	13	12	11	10	9	8	7	6	5	4	3	2	1	0
Read/Write	Ch31	Ch30	Ch29	Ch28	Ch27	Ch26	Ch25	Ch24	Ch23	Ch22	Ch21	Ch20	Ch19	Ch18	Ch17	Ch16
Read/Write	Ch63	Ch62	Ch61	Ch60	Ch59	Ch58	Ch57	Ch56	Ch55	Ch54	Ch53	Ch52	Ch51	Ch50	Ch49	Ch48

Negative Mask Register Port 1/3

The Negative Mask Register for Port 1/3 (base + 2A_h) can be read or written. If bit 4 of the Control/Status Register is low ("0"), Port 1 data is accessed. If bit 4 is high ("1"), Port 3 data will be accessed. The operation of the Negative Mask Register for Port 1/3 is identical to those of Port 0/2.

Negative Mask Register Port 1/3 (Channels 16-31/48-63) (base + 2Ah)

b + 2A _h	15	14	13	12	11	10	9	8	7	6	5	4	3	2	1	0
Read/Write	Ch31	Ch30	Ch29	Ch28	Ch27	Ch26	Ch25	Ch24	Ch23	Ch22	Ch21	Ch20	Ch19	Ch18	Ch17	Ch16
Read/Write	Ch63	Ch62	Ch61	Ch60	Ch59	Ch58	Ch57	Ch56	Ch55	Ch54	Ch53	Ch52	Ch51	Ch50	Ch49	Ch48

Debounce Clock Register Port 0 and Port 1/ Port 2 and Port 3

The Debounce Clock Register (base + 2E_h) can be read or written. This register is a mirror image of the Debounce Clock Register at base + 1E_h. Refer to that register for an explanation of its operation.

Debounce Clock Register Port 0 and Port 1/Port 2 and Port 3 (base + 2Eh)

b + 2E _h	15	14	13	12	11	10	9	8	7	6	5	4	3	2	1	0
Write	No Effect											DEBOUNCE TIME				
Read	Always Returns FFF _h										0	0	0	DEBOUNCE TIME		

When BS = 0 in the Status/Control Register, the debounce clock for Port 0 and Port 1 are accessed. Port 0 and Port 1 use the same debounce clock. With BS = 0 any value programmed into or read from this register will be the same as the register at b + 2E_h.

When BS = 1 in the Status/Status Register, the debounce clock for Port 2 and Port 3 are accessed. Port 2 and Port 3 use the same debounce clock. With BS = 1 any value programmed into or read from this register will be the same as the register at b + 1E_h.

Register Value	Bit Pattern (Hex)	Clock Frequency	Clock Period	Debounce Time (4 - 4.5 Clock Periods)
2 (or 0) Default	0002 _h	250 kHz	4 μ S	16 - 18 μ S
3 (or 1)	0003 _h	125 kHz	8 μ S	32 - 36 μ S
4	0004 _h	62.5 kHz	16 μ S	64 - 72 μ S
5	0005 _h	31.25 kHz	32 μ S	128 - 144 μ S
6	0006 _h	15.63 kHz	64 μ S	256 - 288 μ S
7	0007 _h	7.81 kHz	128 μ S	512 - 576 μ S
8	0008 _h	3.90 kHz	256 μ S	1.0 - 1.13 mS
9	0009 _h	1.95 kHz	512 μ S	2.0 - 2.26 mS
10	000A _h	976 Hz	1 mS	4.1 - 4.6 mS
11	000B _h	488 Hz	2 mS	8.2 - 9.2 mS
12	000C _h	244 Hz	4.1 mS	16.4 - 18.4 mS
13	000D _h	122 Hz	8.2 mS	32.8 - 36.9 mS
14	000E _h	61 Hz	16.4 mS	65.5 - 73.8 mS
15	000F _h	30.5 Hz	32.8 mS	131 - 148 mS
16	0010 _h	15.3 Hz	65.5 mS	262 - 294 mS
17	0011 _h	7.63 Hz	131 mS	524 - 590 mS
18	0012 _h	3.82 Hz	262 mS	1.05 - 1.18 S
19	0013 _h	1.91 Hz	524 mS	2.1 - 2.36 S
20	0014 _h	0.954 Hz	1.05 S	4.2 - 4.72 S
21	0015 _h	0.477 Hz	2.1 S	8.39 - 9.43 S
22	0016 _h	0.238 Hz	4.2 S	16.8 - 18.9 S
23	0017 _h	0.119 Hz	8.39 S	33.6 - 37.8 S
24	0018 _h	60 mHz	16.8 S	67.1 - 75 S
25	0019 _h	30 mHz	33.6 S	134 - 150 S
26	001A _h	15 mHz	67.1 S	268 - 300 S
27	001B _h	7.5 mHz	134 S	537 - 600 S
28	001C _h	3.7 mHz	268 S	1074 - 1200 S
29	001D _h	1.9 mHz	537 S	2147 - 2400 S
30	001E _h	931 μ Hz	1074 S	4295 - 4800 S
31	001F _h	466 μ Hz	2147 s	8590 - 9600 s

Power On/Reset Conditions

A soft reset is generated when the reset bit in the control register is set active and then released. A hard reset is generated when the SYSRESET line on the backplane is active. In either of these cases all control bits will be set to "0". This includes bits in the Control/Status Register, Command Registers, the mask registers, and the Debounce Clock Register (which are actually set to 2).

Programming Examples

The following C language program demonstrates how to program at the register level. The program reads the ID, Device Type, and Status registers. This program was written and tested in Microsoft Visual C++ but should compile under any standard ANSI C compiler.

To run this program you must have the Agilent SICL library, the Agilent VISA library, an GPIB interface module installed in your PC, and an Agilent E1406 Command Module.

```
#include <visa.h>
#include <stdio.h>
#include <stdlib.h>

ViSession viRM,E1459;
int main()
{
    unsigned short id_reg,dt_reg ;           /* ID & Device Type Registers */
    unsigned short stat_reg ;               /* Status Register register */

    ViStatus errStatus;                     /*Status from each VISA call*/

    /* Open the default resource manager */
    errStatus = viOpenDefaultRM ( &viRM);
    if (VI_SUCCESS > errStatus){
        printf("ERROR: viOpenDefaultRM() returned 0x%x\n",errStatus);
        return errStatus;}

    /* Open the Module instrument session ; Logical Address = 8 */
    errStatus = viOpen(viRM,"GPIB-VXI0::8",VI_NULL,VI_NULL,&E1459);
    if (VI_SUCCESS > errStatus){
        printf("ERROR: viOpen() returned 0x%x\n",errStatus);
        return errStatus;}

    /* read and print the module's ID Register */
    errStatus = viln16(E1459,VI_A16_SPACE,0x00,&id_reg);
    if (VI_SUCCESS > errStatus){
        printf("ERROR: viln16() returned 0x%x\n",errStatus);
        return errStatus;}
    printf("ID register = 0x%4X\n", id_reg);
}
```

```

        /* read and print the module's Device Type Register */
errStatus = viIn16(E1459,VI_A16_SPACE,0x02,&dt_reg);
if (VI_SUCCESS > errStatus){
    printf("ERROR: viIn16() returned 0x%x\n",errStatus);
    return errStatus;}
printf("Device Type register = 0x%4X\n", dt_reg);

        /* read and print the module's Status Register */
errStatus = viIn16(E1459,VI_A16_SPACE,0x04,&stat_reg);
if (VI_SUCCESS > errStatus){
    printf("ERROR: viIn16() returned 0x%x\n",errStatus);
    return errStatus;}
printf("Status register = 0x%4X\n", stat_reg);

        /* Close the Module Instrument Session */
errStatus = viClose (E1459);
if (VI_SUCCESS > errStatus) {
    printf("ERROR: viClose() returned 0x%x\n",errStatus);
    return 0;}

        /* Close the Resource Manager Session */
errStatus = viClose (viRM);
if (VI_SUCCESS > errStatus) {
    printf("ERROR: viClose() returned 0x%x\n",errStatus);
    return 0;}

return VI_SUCCESS;
}

```

Output and Edge Detection Examples

The following three programming examples demonstrate edge detection, DAV, and mixed programming methods.

Edge Interrupt Example

This example is coded in BASIC for a System 9000 (Series 300) linked to a Agilent E1406 Command Module via GPIB. The example enables all four channel ports to detect both positive and negative edges on any channel of any port. Any edge will consequently generate an interrupt. When idle, the program will loop and continuously display the WORD DATA REGISTERS for all four channel ports and the EDGE INTERRUPT STATUS REGISTER. (This shows the static state of each channel input.) On interrupt, the program will alternately display the EDGE DETECT REGISTERS of each port, and the EDGE INTERRUPT STATUS REGISTER.

```

90 CLEAR SCREEN
100 DIM A$(40)
110 Vxi_address=70900
120 !
130 CLEAR 7
140 OUTPUT Vxi_address;"*RST;*CLS"    ! reset E1406

```

```

150 !
160 REPEAT
170 OUTPUT Vxi_address;"SYST:ERR?"
180 ENTER Vxi_address;Error
190 PRINT "E1406 Reports Error: ";Error
200 UNTIL (Error=0)
210 !
220 OUTPUT Vxi_address;"VXI:WRITE 128,4,1"! reset E1459A
230 WAIT .1
240 OUTPUT Vxi_address;"VXI:WRITE 128,4,0"! un-reset E1459A
250 WAIT .1
260 !
265 ! unmask all 16 pos bits for port 0
270 OUTPUT Vxi_address;"VXI:WRITE 128,24,-1"
275 ! unmask all 16 neg bits for port 0
280 OUTPUT Vxi_address;"VXI:WRITE 128,26,-1"
285 ! unmask all 16 pos bits for port 1
290 OUTPUT Vxi_address;"VXI:WRITE 128,40,-1"
295 ! unmask all 16 neg bits for port 1
300 OUTPUT Vxi_address;"VXI:WRITE 128,42,-1"
310 !
315 ! set debounce to 16 uS (250KHz) for ports 0/1
320 OUTPUT Vxi_address;"VXI:WRITE 128,30,2"
330 !
340 OUTPUT Vxi_address;"VXI:WRITE 128,4,16"! port 2/3 select
350 !
355 ! unmask all 16 pos bits for port 2
360 OUTPUT Vxi_address;"VXI:WRITE 128,24,-1"
365 ! unmask all 16 neg bits for port 2
370 OUTPUT Vxi_address;"VXI:WRITE 128,26,-1"
375 ! unmask all 16 pos bits for port 3
380 OUTPUT Vxi_address;"VXI:WRITE 128,40,-1"
385 ! unmask all 16 neg bits for port 3
390 OUTPUT Vxi_address;"VXI:WRITE 128,42,-1"
400 !
405 ! set debounce to 16 uS (250KHz) for ports 2/3
410 OUTPUT Vxi_address;"VXI:WRITE 128,46,2"
420 !
430 OUTPUT Vxi_address;"*SRE 128"
440 OUTPUT Vxi_address;"STAT:OPER:ENAB 256"
450 OUTPUT Vxi_address;"DIAG:INT:SET1 ON"
460 OUTPUT Vxi_address;"DIAG:INT:ACT ON"
470 !
480 OUTPUT Vxi_address;"*OPC?"
490 ENTER Vxi_address;Done
500 !
510 ON INTR 7 GOSUB Service
520 !
530 OUTPUT Vxi_address;"VXI:WRITE 128,16,1"! edge enable, port 2
540 OUTPUT Vxi_address;"VXI:WRITE 128,32,1"! edge enable, port 3
550 !
560 OUTPUT Vxi_address;"VXI:WRITE 128,4,0" ! port 0/1 select
570 !
580 OUTPUT Vxi_address;"VXI:WRITE 128,16,1"! edge enable, port 0
590 OUTPUT Vxi_address;"VXI:WRITE 128,32,1"! edge enable, port 1
600 !
610 ENABLE INTR 7;2
615 ! int enable, port 0/1 select

```

```

620 OUTPUT Vxi_address;"VXI:WRITE 128,4,32"
630 !
640 LOOP
650   DISABLE INTR 7
660   !
665   !int enabled, port 0/1 select
670   OUTPUT Vxi_address;"VXI:WRITE 128,4,32"
680   !
690   OUTPUT Vxi_address;"VXI:READ? 128,18!" get data register port 0
700   ENTER Vxi_address;G0
710   OUTPUT Vxi_address;"VXI:READ? 128,34!" get data register port 1
720   ENTER Vxi_address;G1
730   !
735   ! int enabled, port 2/3 select
740   OUTPUT Vxi_address;"VXI:WRITE 128,4,48"
750   !
760   OUTPUT Vxi_address;"VXI:READ? 128,18" ! get data register port 2
770   ENTER Vxi_address;G2
780   OUTPUT Vxi_address;"VXI:READ? 128,34" ! get data register port 3
790   ENTER Vxi_address;G3
800   !
810   OUTPUT Vxi_address;"VXI:READ? 128,6" ! get int status register
820   ENTER Vxi_address;E
830   ENABLE INTR 7;2
840   Istat=BINAND(E,15)
850   DISP "Port 0: ";G0,"Port 1: ";G1,"Port 2: ";G2,"Port 3: ";G3,"Intr: ";Istat
860 END LOOP
870 !
880 Service: !
890   DISABLE INTR 7
895   ! disable E1459A ints, port 0/1 select
900   OUTPUT Vxi_address;"VXI:WRITE 128,4,0"
910   !
920   A=SPOLL(Vxi_address)
930   OUTPUT Vxi_address;"STAT:OPER:EVEN?"
940   ENTER Vxi_address;S_op
950   OUTPUT Vxi_address;"DIAG:INT:RESP?"
960   ENTER Vxi_address;R
970   !
980 REPEAT
990   OUTPUT Vxi_address;"SYST:ERR?"
1000  ENTER Vxi_address;Ec,A$
1010 UNTIL Ec=0
1020 !
1030 N=N+1
1040 PRINT "Int #: ";N
1050 !
1060 OUTPUT Vxi_address;"VXI:READ? 128,6" ! get int status register
1070 ENTER Vxi_address;A
1080 !
1090 A=BINAND(A,15)
1100 PRINT "Edge Int Status: ";A
1110 !
1115 ! get pos edge register port 0
1120 OUTPUT Vxi_address;"VXI:READ? 128;20"
1130 ENTER Vxi_address;A
1135 ! get neg edge register port 0

```



```

1140 OUTPUT Vxi_address;"VXI:READ? 128,22"
1150 ENTER Vxi_address;B
1160 PRINT "Wrd 0 Pos Edge: ";A
1170 PRINT "Wrd 0 Neg Edge: ";B
1180 !
1190 OUTPUT Vxi_address;"VXI:READ? 128,6"! get int status register
1200 ENTER Vxi_address;E
1210 Istat=BINAND(E,15)
1220 PRINT "Edge Int Status: ";Istat
1230 !
1235 ! get pos edge register port 1
1240 OUTPUT Vxi_address;"VXI:READ? 128,36"
1250 ENTER Vxi_address;A
1255 ! get neg edge register port 1
1260 OUTPUT Vxi_address;"VXI:READ? 128,38"
1270 ENTER Vxi_address;B
1280 PRINT "Wrd 1 Pos Edge: ";A
1290 PRINT "Wrd 1 Neg Edge: ";B
1300 !
1310 OUTPUT Vxi_address;"VXI:READ? 128,6"! get int status register
1320 ENTER Vxi_address;E
1330 Istat=BINAND(E,15)
1340 PRINT "Edge Int Status: ";Istat
1350 !
1355 ! int disable, port 2/3 select
1360 OUTPUT Vxi_address;"VXI:WRITE 128,4,16"
1370 !
1375 ! get pos edge register port 2
1380 OUTPUT Vxi_address;"VXI:READ? 128,20"
1390 ENTER Vxi_address;A
1395 ! get neg edge register port 2
1400 OUTPUT Vxi_address;"VXI:READ? 128,22"
1410 ENTER Vxi_address;B
1420 PRINT "Wrd 2 Pos Edge: ";A
1430 PRINT "Wrd 2 Neg Edge: ";B
1440 !
1450 OUTPUT Vxi_address;"VXI:READ? 128,6"! get int status register
1460 ENTER Vxi_address;E
1470 Istat=BINAND(E,15)
1480 PRINT "Edge Int Status: ";Istat
1490 !
1495 ! get pos edge register port 3
1500 OUTPUT Vxi_address;"VXI:READ? 128,36"
1510 ENTER Vxi_address;A
1515 ! get neg edge register port 3
1520 OUTPUT Vxi_address;"VXI:READ? 128,38"
1530 ENTER Vxi_address;B
1540 PRINT "Wrd 3 Pos Edge: ";A
1550 PRINT "Wrd 3 Neg Edge: ";B
1560 !
1570 OUTPUT Vxi_address;"VXI:READ? 128,6"! get int status register
1580 ENTER Vxi_address;E
1590 Istat=BINAND(E,15)
1600 PRINT "Edge Int Status: ";Istat
1610 !
1620 PRINT
1630 !
1640 OUTPUT Vxi_address;"DIAG:INT:SET1 ON"

```

```

1650 OUTPUT Vxi_address;"DIAG:INT:ACT ON"
1660 OUTPUT Vxi_address;"*OPC?"
1670 ENTER Vxi_address;Done
1680 !
1690 ENABLE INTR 7;2
1695 ! int enabled, select port 0
1700 OUTPUT Vxi_address;"VXI:WRITE 128,4,32"
1710 !
1720 RETURN
1730 END

```

DAV Interrupt Example

This example is coded in RMB for an HP System 9000 (Series 300) linked to an E1406 Command Module via GPIB. The example enables all four channel ports to capture channel data (and generate an interrupt) on the occurrence of an external capture clock at a corresponding port. When idle, the program will loop and continuously display the DAV STATUS REGISTER. On interrupt, the DAV STATUS REGISTER and all four port DATA REGISTERS are displayed.

```

70 CLEAR SCREEN
80 DIM A$(40)
90 Vxi_address=70900
100 !
110 CLEAR 7
120 OUTPUT Vxi_address;"*RST;*CLS"      ! reset E1406
130 !
140 REPEAT
150   OUTPUT Vxi_address;"SYST:ERR?"
160   ENTER Vxi_address;Error
170   PRINT "E1406 Reports Error: ";Error
180   UNTIL (Error=0)
190 !
200 OUTPUT Vxi_address;"VXI:WRITE 128,4,1"! reset E1459A
210 WAIT .1
220 OUTPUT Vxi_address;"VXI:WRITE 128,4,0"! un-reset E1459A
230 WAIT .1
240 !
245 ! dav enable, ext clk, port 0
250 OUTPUT Vxi_address;"VXI:WRITE 128,16,6"
255 ! mask off all 16 pos bits for port 0
260 OUTPUT Vxi_address;"VXI:WRITE 128,24,0"
265 ! mask off all 16 neg bits for port 0
270 OUTPUT Vxi_address;"VXI:WRITE 128,26,0"
280 !
285 ! dav enable, ext clk, port 1
290 OUTPUT Vxi_address;"VXI:WRITE 128,32,6"
295 ! mask off all 16 pos bits for port 1
300 OUTPUT Vxi_address;"VXI:WRITE 128,36,0"
305 ! mask off all 16 neg bits for port 1
310 OUTPUT Vxi_address;"VXI:WRITE 128,38,0"
320 !
325 ! set debounce to 16 uS (250 KHz) for ports 0/1
330 OUTPUT Vxi_address;"VXI:WRITE 128,30,2"
340 !
345 ! E1459A ints disabled, port 2/3 select
350 OUTPUT Vxi_address;"VXI:WRITE 128,4,16"
360 !

```

```

365 ! dav enable, ext clk, port 2
370 OUTPUT Vxi_address;"VXI:WRITE 128,16,6"
375 ! mask off all 16 pos bits for port 2
380 OUTPUT Vxi_address;"VXI:WRITE 128,24,0"
385 ! mask off all 16 neg bits for port 2
390 OUTPUT Vxi_address;"VXI:WRITE 128,26,0"
400 !
405 ! dav enable, ext clk, port 3
410 OUTPUT Vxi_address;"VXI:WRITE 128,32,6"
415 ! mask off all 16 pos bits for port 3
420 OUTPUT Vxi_address;"VXI:WRITE 128,36,0"
425 ! mask off all 16 neg bits for port 3
430 OUTPUT Vxi_address;"VXI:WRITE 128,38,0"
440 !
445 ! set debounce to 16 uS (250 KHz) for ports 2/3
450 OUTPUT Vxi_address;"VXI:WRITE 128,30,2"
460 !
470 OUTPUT Vxi_address;"*SRE 128"
480 OUTPUT Vxi_address;"STAT:OPER:ENAB 256"
490 OUTPUT Vxi_address;"DIAG:INT:SET1 ON"
500 OUTPUT Vxi_address;"DIAG:INT:ACT ON"
510 !
520 OUTPUT Vxi_address;"*OPC?"
530 ENTER Vxi_address;Done
540 !
550 ON INTR 7 GOSUB Service
560 ENABLE INTR 7;2
565 ! dav int enable, port 0/1 select
570 OUTPUT Vxi_address;"VXI:WRITE 128,4,64"
580 !
590 LOOP
600 DISABLE INTR 7
610 OUTPUT Vxi_address;"VXI:READ? 128,8" get dav status register
620 ENTER Vxi_address;E
630 ENABLE INTR 7;2
640 Istat=BINAND(E,15)
650 DISP "DAV Status Reg: ";Istat
660 END LOOP
670 !
680 Service: !
690 DISABLE INTR 7
695 ! disable E1459A ints, port 0/1 select
700 OUTPUT Vxi_address;"VXI:WRITE 128,4,0"
710 !
720 A=SPOLL(Vxi_address)
730 OUTPUT Vxi_address;"STAT:OPER:EVEN?"
740 ENTER Vxi_address;S_op
750 OUTPUT Vxi_address;"DIAG:INT:RESP?"
760 ENTER Vxi_address;R
770 !
780 REPEAT
790 OUTPUT Vxi_address;"SYST:ERR?"
800 ENTER Vxi_address;Ec,A$
810 UNTIL Ec=0
820 !
830 N=N+1
840 PRINT "Int #: ";N
850 !

```

```

860 OUTPUT Vxi_address;"VXI:READ? 128,8!" get dav status register
870 ENTER Vxi_address;A
880 !
890 A=BINAND(A,15)
900 PRINT "DAV Status: ";A
910 !
915 ! get dav data register, port 0
920 OUTPUT Vxi_address;"VXI:READ? 128,18"
930 ENTER Vxi_address;A
940 PRINT "DAV Data Reg Port 0: ";A
950 !
955 ! get dav data register, port 1
960 OUTPUT Vxi_address;"VXI:READ? 128,34"
970 ENTER Vxi_address;A
980 PRINT "DAV Data Reg Port 1: ";A
990 !
995 ! E1459A ints disabled, port 2/3 select
1000 OUTPUT Vxi_address;"VXI:WRITE 128,4,16"
1010 !
1015 ! get dav data register, port 2
1020 OUTPUT Vxi_address;"VXI:READ? 128,18"
1030 ENTER Vxi_address;A
1040 PRINT "DAV Data Reg Port 2: ";A
1050 !
1055 ! get dav data register, port 3
1060 OUTPUT Vxi_address;"VXI:READ? 128,34"
1070 ENTER Vxi_address;A
1080 PRINT "DAV Data Reg Port 3: ";A
1090 !
1100 OUTPUT Vxi_address;"VXI:READ? 128,8!" get dav status register
1110 ENTER Vxi_address USING "#,K";E
1120 Istat=BINAND(E,15)
1130 PRINT "DAV Status Reg: ";Istat
1140 PRINT
1150 !
1160 OUTPUT Vxi_address;"DIAG:INT:SET1 ON"
1170 OUTPUT Vxi_address;"DIAG:INT:ACT ON"
1180 OUTPUT Vxi_address;"*OPC?"
1190 ENTER Vxi_address;Done
1200 !
1210 ENABLE INTR 7;2
1215 ! dav int enabled, port 0/1 select
1220 OUTPUT Vxi_address;"VXI:WRITE 128,4,64"
1230 !
1240 RETURN
1250 END

```

Mixed Interrupt Example

This example is coded in RMB for an HP System 9000 (Series 300) linked to a E1406 Command Module via GPIB. The example enables all four channel ports to detect both positive and negative edges on the high order eight channels of any port. (Any unmasked edge will generate an interrupt.) The low order eight channels of each port are defined for capture of an eight bit data byte. (An interrupt will also be generated on the occurrence of an external capture clock at any channel port.) When idle, the program will loop and continuously display the EDGE INTERRUPT STATUS REGISTER and the DATA AVAILABLE REGISTER. On interrupt, the program will display the EDGE DETECT REGISTERS and CHANNEL

DATA REGISTERS for each port.

```
100 CLEAR SCREEN
110 DIM A$(40)
120 Vxi_address=70900
130 !
140 CLEAR 7
150 OUTPUT Vxi_address;"*RST;*CLS"      ! reset E1406
160 !
170 REPEAT
180   OUTPUT Vxi_address;"SYST:ERR?"
190   ENTER Vxi_address;Error
200   PRINT "E1406 Reports Error: ";Error
210 UNTIL (Error=0)
220 !
230 OUTPUT Vxi_address;"VXI:WRITE 128,4,1" reset E1459A
240 WAIT .1
250 OUTPUT Vxi_address;"VXI:WRITE 128,4,0" un-reset E1459A
260 WAIT .1
270 !
275 ! dav enable, ext clk, edge enable, port 0
280 OUTPUT Vxi_address;"VXI:WRITE 128,16,7"
285 ! unmask high order 8 pos bits for port 0
290 OUTPUT Vxi_address;"VXI:WRITE 128,24,-256"
295 ! unmask high order 8 neg bits for port 0
300 OUTPUT Vxi_address;"VXI:WRITE 128,26,-256"
310 !
315 ! dav enable, ext clk, edge enable, port 1
320 OUTPUT Vxi_address;"VXI:WRITE 128,32,7"
325 ! unmask high order 8 pos bits for port 1
330 OUTPUT Vxi_address;"VXI:WRITE 128,36,-256"
335 ! unmask high order 8 neg bits for port 1
340 OUTPUT Vxi_address;"VXI:WRITE 128,38,-256"
350 !
355 ! set debounce to 16 uS (250 KHz) for ports 0/1
360 OUTPUT Vxi_address;"VXI:WRITE 128,30,2"
370 !
375 ! E1459A ints disabled, port 2/3 select
380 OUTPUT Vxi_address;"VXI:WRITE 128,4,16"
390 !
395 ! dav enable, ext clk, edge enable, port 2
400 OUTPUT Vxi_address;"VXI:WRITE 128,16,7"
405 ! unmask high order 8 pos bits for port 2
410 OUTPUT Vxi_address;"VXI:WRITE 128,24,-256"
415 ! unmask high order 8 neg bits for port 2
420 OUTPUT Vxi_address;"VXI:WRITE 128,26,-256"
430 !
435 ! dav enable, ext clk, edge enable, port 3
440 OUTPUT Vxi_address;"VXI:WRITE 128,32,7"
445 ! unmask high order 8 pos bits for port 3
450 OUTPUT Vxi_address;"VXI:WRITE 128,36,-256"
455 ! unmask high order 8 neg bits for port 3
460 OUTPUT Vxi_address;"VXI:WRITE 128,38,-256"
470 !
475 ! set debounce to 16 uS (250 KHz) for ports 2/3
480 OUTPUT Vxi_address;"VXI:WRITE 128,46,2"
490 !
500 OUTPUT Vxi_address;"*SRE 128"
```

```

510 OUTPUT Vxi_address;"STAT:OPER:ENAB 256"
520 OUTPUT Vxi_address;"DIAG:INT:SET1 ON"
530 OUTPUT Vxi_address;"DIAG:INT:ACT ON"
540 !
550 OUTPUT Vxi_address;"*OPC?"
560 ENTER Vxi_address;Done
570 !
580 ON INTR 7 GOSUB Service
590 ENABLE INTR 7;2
595 ! dav/edge int enable, port 0/1 select
600 OUTPUT Vxi_address;"VXI:WRITE 128,4,96"
610 !
620 LOOP
630   DISABLE INTR 7
635   ! get edge int status register
640   OUTPUT Vxi_address;"VXI:READ? 128,6"
650   ENTER Vxi_address;G
660   OUTPUT Vxi_address;"VXI:READ? 128,8"! get dav status register
670   ENTER Vxi_address;E
680   ENABLE INTR 7;2
690   Istat=BINAND(G,15)
700   Dstat=BINAND(E,15)
710   DISP "DAV Status Reg: ";Dstat,"EInt Status Reg: ";Istat
720 END LOOP
730 !
740 Service: !
750   DISABLE INTR 7
755   ! disable E1459A ints, port 0/1 select
760   OUTPUT Vxi_address;"VXI:WRITE 128,4,0"
770   !
780   A=SPOLL(Vxi_address)
790   OUTPUT Vxi_address;"STAT:OPER:EVEN?"
800   ENTER Vxi_address;S_op
810   OUTPUT Vxi_address;"DIAG:INT:RESP?"
820   ENTER Vxi_address;R
830   !
840   REPEAT
850     OUTPUT Vxi_address;"SYST:ERR?"
860     ENTER Vxi_address;Ec,A$
870     UNTIL Ec=0
880     !
890     N=N+1
900     PRINT "Int #: ";N
910     !
915     ! get dav status register
920     OUTPUT Vxi_address;"VXI:READ? 128,8"
930     ENTER Vxi_address;A
940     !
950     A=BINAND(A,15)
960     PRINT "DAV Status: ";A
970     !
975     ! get dav data register, port 0
980     OUTPUT Vxi_address;"VXI:READ? 128,18"
990     ENTER Vxi_address;A
1000    PRINT "DAV Data Reg Port 0: ";A
1010    !
1015    ! get pos edge register, port 0
1020    OUTPUT Vxi_address;"VXI:READ? 128,20"

```

```

1030 ENTER Vxi_address;A0
1035 ! get neg edge register, port 0
1040 OUTPUT Vxi_address;"VXI:READ? 128,22"
1050 ENTER Vxi_address;A1
1060 !
1065 ! get dav data register, port 1
1070 OUTPUT Vxi_address;"VXI:READ? 128,34"
1080 ENTER Vxi_address;A
1090 PRINT "DAV Data Reg Port 1: ";A
1100 !
1105 ! get pos edge register, port 1
1110 OUTPUT Vxi_address;"VXI:READ? 128,36"
1120 ENTER Vxi_address;B0
1125 ! get neg edge register, port 1
1130 OUTPUT Vxi_address;"VXI:READ? 128,38"
1140 ENTER Vxi_address;B1
1150 !
1155 ! E1459A ints disabled, port 2/3 select
1160 OUTPUT Vxi_address;"VXI:WRITE 128,4,16"
1170 !
1175 ! get dav data register, port 2
1180 OUTPUT Vxi_address;"VXI:READ? 128,18"
1190 ENTER Vxi_address;A
1200 PRINT "DAV Data Reg Port 2: ";A
1210 !
1215 ! get pos edge register, port 2
1220 OUTPUT Vxi_address;"VXI:READ? 128,20"
1230 ENTER Vxi_address;C0
1235 ! get neg edge register, port 2
1240 OUTPUT Vxi_address;"VXI:READ? 128,22"
1250 ENTER Vxi_address;C1
1260 !
1265 ! get dav data register, port 3
1270 OUTPUT Vxi_address;"VXI:READ? 128,34"
1280 ENTER Vxi_address;A
1290 PRINT "DAV Data Reg Port 3: ";A
1300 !
1305 ! get pos edge register, port 3
1310 OUTPUT Vxi_address;"VXI:READ? 128,36"
1320 ENTER Vxi_address;D0
1325 ! get neg edge register, port 3
1330 OUTPUT Vxi_address;"VXI:READ? 128,38"
1340 ENTER Vxi_address;D1
1350 !
1355 ! get dav status register
1360 OUTPUT Vxi_address;"VXI:READ? 128,8"
1370 ENTER Vxi_address USING "#,K";E
1380 Dstat=BINAND(E,15)
1390 PRINT "DAV Status Reg: ";Dstat
1400 PRINT
1410 !
1415 ! get edge int status register
1420 OUTPUT Vxi_address;"VXI:READ? 128,6"
1430 ENTER Vxi_address;A
1440 A=BINAND(A,15)
1450 PRINT "EInt Status: ";A
1460 !
1465 ! print wrd 0 edge registers

```

```

1470 A=BINAND(A0,-256)
1480 PRINT "Wrd 0 Pos Edge: ";A
1490 A=BINAND(A1,-256)
1500 PRINT "Wrd 0 Neg Edge: ";A
1510 !
1515 ! get edge int status register
1520 OUTPUT Vxi_address;"VXI:READ? 128,6"
1530 ENTER Vxi_address;A
1540 A=BINAND(A,15)
1550 PRINT "EInt Status: ";A
1560 !
1565 ! print wrd 1 edge registers
1570 B=BINAND(B0,-256)
1580 PRINT "Wrd 1 Pos Edge: ";B
1590 B=BINAND(B1,-256)
1600 PRINT "Wrd 1 Neg Edge: ";B
1610 !
1615 ! get edge int status register
1620 OUTPUT Vxi_address;"VXI:READ? 128,6"
1630 ENTER Vxi_address;A
1640 A=BINAND(A,15)
1650 PRINT "EInt Status: ";A
1660 !
1665 ! print wrd 2 edge registers
1670 C=BINAND(C0,-256)
1680 PRINT "Wrd 2 Pos Edge: ";C
1690 C=BINAND(C1,-256)
1700 PRINT "Wrd 2 Neg Edge: ";C
1710 !
1715 ! get edge int status register
1720 OUTPUT Vxi_address;"VXI:READ? 128,6"
1730 ENTER Vxi_address;A
1740 A=BINAND(A,15)
1750 PRINT "EInt Status: ";A
1760 !
1765 ! print wrd 3 edge registers
1770 D=BINAND(D0,-256)
1780 PRINT "Wrd 3 Pos Edge: ";D
1790 D=BINAND(D1,-256)
1800 PRINT "Wrd 3 Neg Edge: ";D
1810 !
1815 ! get edge int status register
1820 OUTPUT Vxi_address;"VXI:READ? 128,6"
1830 ENTER Vxi_address;A
1840 A=BINAND(A,15)
1850 PRINT "EInt Status: ";A
1860 PRINT
1870 !
1880 OUTPUT Vxi_address;"DIAG:INT:SET1 ON"
1890 OUTPUT Vxi_address;"DIAG:INT:ACT ON"
1900 OUTPUT Vxi_address;"*OPC?"
1910 ENTER Vxi_address;Done
1920 !
1930 ENABLE INTR 7;2
1935 !dav/edge int enabled, port 0/1 select
1940 OUTPUT Vxi_address;"VXI:WRITE 128,4,96"
1950 !
1960 RETURN

```

1970 END

Appendix C

Error Messages

The following table lists error message and possible cause associated with the Agilent E1459A Module.

Error	Description
-104, "Data type error"	<mask> is not in decimal format.
-109, "Missing parameter"	A command does not include a required parameter (parameter cannot be defaulted). For example, SENSE:EVENT:PORT0:PEDGe:ENAB - this command is missing the value of <mask>.
-113, "Undefined Header"	An attempt to execute an unrecognized command
-123, "Numeric overflow"	Data for a parameter is out of range. For example, the positive edge detect enable mask parameter is less than -32768 or greater than +32767.
131, "Unrecognized suffix"	Incorrect suffix such as SECONDS instead of SEC.
-141, "Invalid character data"	Parameter specified is not EXTERNAL, INTERNAL, MINIMUM, MAXIMUM, DEFAULT, 0, 1, ON, OFF, DAV, NEDG, PEDG, etc.
-221, "Settings conflict"	Clock source on a port is INTERNAL and an attempt was made to enable a Data Available event OR a DAV event is enabled and an attempt is made to set the clock source to INTERNAL.
-222, "Data out of range"	Data for a parameter is outside of limits. For example, an attempt to set debounce time to 10000 seconds.
-230, "Data corrupt or stale"	Data available (DAV) is FALSE. New data has not been clocked into the input circuitry since the input circuitry has been reprogrammed or since the last current value was read.
2025, "Invalid port number for access TYPE"	Port not 0 or 2 for LWORD access.
2026, "Port number out of range"	Specified port is not 0, 1, 2, or 3.
2027, "Invalid bit number for access TYPE"	Bit number must be in the range of 0 to 15 for WORD and 0 to 31 for LWORD.
2029, "Event is not an OPERATION status event"	The event specified is not DATAVAILABLE, NEDGE, or PEDGE.
2030, "Event is not an QUESTIONABLE status event"	The event specified is not VDATA.
2031, "Bit number out of range"	Bit number must be between 0 and 15.
2032, "Totalizers not installed"	TOTALIZE bit set to 1 but totalizers are not installed on card.
2034, "Register is read only"	Attempt to write to a read only register.
3000, "Illegal while initiated"	Trigger system must be in idle state if the FIFO trigger is EVENT.

Symbols

*CLS, 70
*DMC, 70
*EMC, 70
*EMC?, 70
*ESE, 70
*ESE?, 70
*ESR?, 70
*GMC?, 70
*IDN?, 70
*LMC?, 70
*OPC, 70
*OPC?, 70
*PMC, 70
*RCL, 70
*RMC, 70
*RST, 70
*SAV, 70
*SRE, 70
*SRE?, 70
*STB?, 70
*TRG, 70
*TST?, 70
*WAI, 70

A

Abbreviated Commands, 39
Address, logical, 20

B

Block, terminal, 25

C

C++, 29
Command
 abbreviated, 39
 Common, 39
 common, 70
 format, 39
 implied, 40
 linking, 40
 parameters, 40
 SCPI, 39
 Separator, 39
Commands, 29

Configuration, 19
Connecting Inputs, 22

D

Data Capture, 17
Debounce
 input processing, 14
 parameters, 14
Description of module, 11
DIAGnostic
 SYSReset
 ENABLE, 41
 ENABLE?, 42
 STATe?, 41
Digital Input Mode, 32
DISPlay
 MONitor
 PORT, 43
 AUTO, 44
 AUTO?, 44
 PORT?, 44
 STATe, 45
 STATe?, 45

E

Edge Detection, input, 15
Edge interrupt resolver, 13
Example Program
 Digital Input, 32
 Edge Interrupt, 37
 Reset, 30

F

Field Wiring, 25
Front Panel Markers, 18
Functional description, 11

G

GPIO, Agilent SICL, 29
GPIO, Agilent VISA, 29
GPIO Module, Agilent 82340, 29
GPIO Module, Agilent 82341, 29
GPIO Module, 29

I

IEEE 488.2 Common Commands, [39](#), [70](#)
Implied Commands, [40](#)
Input Data Capture, [17](#)
Input Debounce Processing, [14](#)
Input Edge Detection, [15](#)
Input Isolation, [14](#)
Input Level Selection, [14](#)
Input Thresholds, [21](#)
Input voltage, [11](#)
Input Wiring, [22](#)
INPutn
 CLOCK
 SOURce, [46](#)
 SOURce?, [47](#)
 DEBounce
 TIME, [47](#)
 TIME?, [48](#)
Installation, [19](#), [24](#)
Interrupt Mode, [18](#)
Interrupt Priority Jumper, [20](#)
Interrupt, edge resolver, [13](#)
Isolation, input, [14](#)

J

Jumper, interrupt priority, [20](#)

L

Level Selection, input, [14](#)
Linking Commands, [40](#)
Logical Address, [20](#)

M

Mainframe Installation, [24](#)
Markers, front panel, [18](#)
MEASure
 DIGital
 DATAn
 type
 BITm?, [32](#), [50](#)
 VALue?, [32](#), [49](#)
MEMory
 DELeTe
 MACRo, [51](#)
Module description, [11](#)
Module ID, [30](#)

P

Parameters, command, [40](#)
Polled Mode, [18](#)
Power-on State, [30](#)

R

Reset State, [30](#)
Resolver, [13](#)

S

SCPI, [29](#), [39](#)
Self Test, [30](#)
SENSe
 EVENT
 PORTn
 DAVailable
 ENABLE, [53](#)
 ENABLE?, [53](#)
 DAVailable?, [52](#)
 EDGE
 ENABLE, [54](#)
 ENABLE?, [55](#)
 EDGE?, [54](#)
 NEDGE
 ENABLE, [56](#)
 ENABLE?, [56](#)
 NEDGE?, [55](#)
 PEDGe
 ENABLE, [57](#)
 ENABLE?, [58](#)
 PEDGe?, [57](#)
 PSUMmary
 DAVailable?, [58](#)
 EDGE?, [59](#)
Separator, Command, [39](#)
SICL, Agilent, [29](#)
Standard Command for Programmable Instruments,
 [39](#)
Standard Commands for Programmable Instruments,
 [29](#)
STATus
 OPERation
 ENABLE?, [63](#)
 EVENT?, [63](#)
 PSUMmary
 CONDition?, [63](#)
 ENABLE, [64](#)
 ENABLE?, [64](#)

EVENT?, [65](#)

PRESet, [65](#)

QUESTionable

 CONDition?, [66](#)

 ENABle, [66](#)

 ENABle?, [67](#)

 EVENT?, [67](#)

SYSTem

 CDEscription?, [68](#)

 CTYPe?, [68](#)

 ERRor?, [69](#)

 VERSion?, [69](#)

T

Terminal Block, [25](#)

Thresholds, input, [21](#)

Timer, Watchdog, [14](#), [21](#)

U

User Wiring, [25](#)

V

VISA, Agilent, [29](#)

Voltage, input, [11](#)

W

Watchdog Timer, [14](#), [21](#)

Wiring, [25](#)

Wiring, input, [22](#)

